

For online reference and to download the manuals for your machines HAULOTTE®, go to :
<https://www.e-technical-information.com>
or, scan the QR Code below :



**HS15E - HS4390E - HS15E PRO - HS4390E PRO -
HS18E - HS5390E - HS18E PRO - HS5390E PRO -
MONOCHROME LCD DISPLAY**

Operator's manual

**HS15E - HS4390E -
HS15E PRO - HS4390E PRO -
HS18E - HS5390E -
HS18E PRO - HS5390E PRO -
Monochrome LCD display**



A**FOREWORD**

1 - User responsibility	10
1.1- Owner's responsibility	10
1.2- Employer's responsibility	10
1.3- Trainer's responsibility	10
1.4- Operator's responsibility	11
2 - Safety	12
2.1- Safety instructions	12
2.1.1 - Incorrect use	12
2.1.2 - Falling Hazards	13
2.1.3 - Overturning / Tip-over Hazards	14
2.1.4 - Risk of electric shock (electrocution)	18
2.1.5 - Explosion / Fire Hazards	19
2.1.6 - Crushing / Collision Hazards	19
2.1.7 - Risk of involuntary movements	20
3 - Safety inquiries	21
4 - Incident notification	21
5 - Compliance	22
5.1- Product modification	22
5.1.1 - Implementing manufacturer safety campaigns	22
5.2- Product specifications	22
5.3- Change of Ownership Notification	23
5.4- Declaration of conformity	24

B**FAMILIARIZATION**

1 - General safety	27
1.1- Intended use	27
1.2- Decal content	28
1.3- Symbols and colors	30
1.4- Level of severity	30
1.5- Symbols legend and definitions	31
2 - Models description	32
3 - Primary machine components	34
3.1- Layout	34
3.2- Maintenance support	36
3.3- Ground control box	38
3.3.1 - Layout	38
3.3.2 - Display Panel (LED'S 1 - 10) - Monochrome LCD display	42
3.3.2.1 - Fault and alarm codes	44
3.4- Platform control box	46
3.4.1 - Layout	46
4 - Performance Specifications	50
4.1- Technical characteristics	50
4.2- Working area / Range of motion	54
5 - Decals and markings locations	57

CONTENTS

C**PRE-OPERATION INSPECTION**

1 - Recommendations	73
2 - Working area assessment	73
3 - Inspection and Functional test	74
3.1- Daily inspection	74
4 - Safety functional checks	77
4.1- E-Stop button check	77
4.2- Activation of controls	78
4.3- Fault detector	78
4.3.1 - Indicators/LED's test	78
4.3.2 - Buzzers test	79
4.4- Automatic engine cut-out (If machine equipped with the option Range Extender)	79
4.5- Overload sensing system	79
4.6- Oscillating axles (If equipped)	80
4.7- Slope warning device	80
4.8- Travel speed limitation	81
4.9- On-board electronics	81

D**OPERATION INSTRUCTIONS**

1 - Operation	83
1.1- Introduction	83
1.2- Major description	83
1.3- Operation from the ground control box	83
1.4- Operation from the platform control box	84
2 - Ground control box	85
2.1- To start and stop the machine	85
2.2- Movement control	86
2.3- Additional controls	86
3 - Platform control box	87
3.1- To start and stop the machine	87
3.1.1 - To start the machine	87
3.1.2 - To stop the engine	87
3.2- Drive and steer control	88
3.3- Movement control	90
3.4- Additional controls	90
3.4.1 - Activ' Lighting System	90



CONTENTS

4 - Rescue and emergency procedures	91
4.1 - In case of power loss	91
4.2 - To rescue operator in platform	92
4.2.1 - Operation of overriding system from ground control box	93
4.3 - No power available	94
4.3.1 - Manual emergency lowering procedure	94
5 - Transportation	96
5.1 - Transport configuration	96
5.2 - Machine stowage for transport - HS15 E (HS4390 E) - HS15 E PRO (HS4390 E PRO) - HS18 E (HS5390 E) - HS18 E PRO (HS5390 E PRO)	97
5.3 - Loading by ramp	98
5.4 - Folding guardrails	98
5.4.1 - Description	98
5.4.2 - Safety precautions	98
5.4.3 - Fold down operation	98
5.4.4 - Raising guardrails to working position	107
5.5 - Unloading	108
5.5.1 - Unloading by ramp	108
5.6 - Towing	109
5.6.1 - Brake release	110
5.7 - Storage	113
5.8 - Lifting operation	114
5.8.1 - Procedure for the use of slings HS15 E (HS4390 E) - HS15 E PRO (HS4390 E PRO) - HS18 E (HS5390 E) - HS18 E PRO (HS5390 E PRO)	114
6 - Cold Weather Recommendations	117
6.1 - Hydraulic oil	117
7 - Battery care and maintenance	118
7.1 - Locations	118
7.2 - Battery recharge	120
7.2.1 - On-board charger	120
7.2.2 - Battery charging	120
7.3 - Battery care and maintenance	124
7.3.1 - Filling batteries	124
7.3.1.1 - Procedure to fill the batteries manually	125
7.3.1.2 - Procedure to fill the batteries automatically - Option	126
7.3.2 - Desulfation charge	127
7.4 - Optimise battery life	128



E

GENERAL SPECIFICATIONS

- 1 - Machine dimensions 130**
- 2 - Major component masses 133**
- 3 - Acoustics and vibrations 134**
- 4 - Wheels 135**
 - 4.1 - Technical specifications 135
 - 4.2 - Inspection and maintenance 135
- 5 - Options 138**
 - 5.1 - Activ'Shield Bar Scissors -
SECONDARY GUARDING SYSTEM (if the function is present
and the device is installed in its support) 138
 - 5.1.1 - Description 138
 - 5.1.1.1 - Summary of the indicator states 138
 - 5.1.2 - Characteristics 139
 - 5.1.3 - Safety precautions 140
 - 5.1.4 - Pre-operation inspection 140
 - 5.1.5 - Operation 141
 - 5.1.5.1 - Travel speed limitation
(Activ' Shield Bar Scissors option) 141
 - 5.1.5.2 - Raising speed limitation
(Activ' Shield Bar Scissors option) 142
 - 5.1.6 - Specific decals 143
 - 5.1.7 - Insert the console into its support 143
 - 5.2 - Range Extender 145
 - 5.2.1 - Description 145
 - 5.2.2 - Characteristics 145
 - 5.2.3 - Safety precautions 150
 - 5.2.4 - Pre-operation inspection 150
 - 5.2.5 - Installing / Removing the Range Extender 151
 - 5.2.6 - Specific decals 153
 - 5.3 - Fast Charge 154
 - 5.3.1 - Description 154
 - 5.3.2 - Safety precautions 154
 - 5.3.3 - Specifications 154
 - 5.3.4 - Operation 155
 - 5.4 - Plate holder / Tube holder 156
 - 5.4.1 - Description 156
 - 5.4.2 - Characteristics 156
 - 5.4.2.1 - Plate holder usage 157
 - 5.4.2.2 - Tube holder usage 157
 - 5.4.3 - Safety precautions 158
 - 5.4.4 - Pre-operation inspection 159
 - 5.4.5 - Disassembly - Assembly 160
 - 5.4.6 - Operation 162
 - 5.4.6.1 - Plate/panel holder version 162
 - 5.4.6.2 - Tube/pipe holder version 164
 - 5.4.7 - Strapping (Strap not provided) 166
 - 5.4.8 - Storage of the supports on the platform 167
 - 5.4.9 - Folding guardrails if machine equipped with plate/tube
holder support 167



F

MAINTENANCE

- 1 - General 169**
- 2 - Maintenance Schedule 170**
- 3 - Inspection program 171**
 - 3.1- General program 171
 - 3.2- Daily inspection 172
 - 3.3- Periodic inspection 172
 - 3.4- Reinforced inspection 172
 - 3.5- Major inspection 173
- 4 - Repairs and adjustments 174**

G

OTHER INFORMATION

- 1 - Conditions of warranty 175**
- 2 - Subsidiary contact information 175**
 - 2.1- California warning 176

H

INTERVENTION REGISTER

- 1 - Intervention register 179**

CONTENTS



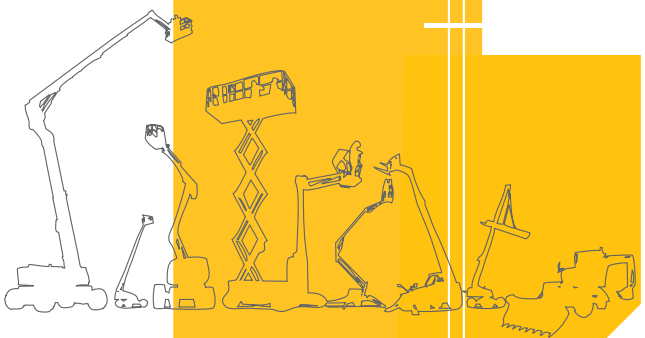

A - Foreword

You have just purchased a HAULOTTE® product and we would like to thank you for your business.

The aerial work platform is a device for lifting people designed and manufactured with the intent to enable users to access overhead elevated temporary workplaces with the necessary tools and equipment. All other uses or alterations/modifications to the aerial work platform must be approved by HAULOTTE®.

This manual shall be considered a permanent component of the machine and shall be kept with the aerial work platform in the designated Manual Holder, at all times.

Safe operation of this product can only be assured if you follow the operating instructions contained in this manual. To ensure the safe and appropriate use of this equipment, only trained personnel are authorised to use and carry out maintenance on the aerial work platform.

We would particularly like to draw your attention to 2 essential points :

- Comply with safety instructions.
- use this equipment within the performance limits specified by this user manual.

With regard to the designation of our equipment, we stress that this is purely for commercial purposes and not to be confused with the technical specifications. Only the specifications in this manual should be used to study the suitability of the equipment for the intended use.

This operator's manual is specific to the HAULOTTE® products listed on the cover page of this manual.



Original language and version :

Manuals in English and French are the original instructions. Manuals in other languages are translations of the original instructions.

The user manual does not replace the necessary training that is required for all of this machine's operators. HAULOTTE® has compiled this manual to assist in safe and efficient operation of the products covered in the manual.

The manual must be available to all operators and must be kept in a legible condition. Additional copies can be ordered from HAULOTTE Services®.

Stay Safe and keep working with HAULOTTE® !

For online reference and to download the manuals for your machines HAULOTTE®, go to :

<https://www.e-technical-information.com>

or, scan the QR Code below :



A - Foreword

1 - User responsibility

1.1 - OWNER'S RESPONSIBILITY

The owner (or hirer) has the obligation to :

- To inform operators of the instructions contained in the Operator's Manual.
- Follow local regulations regarding operation of the machine.
- Replace all manuals or labels that are missing or in poor condition. Additional copies can be ordered from HAULOTTE Services®.
- To establish a preventive maintenance program in accordance with the manufacturer's recommendations, taking into account the environment and severity of use of the machine.
- To perform periodic inspections in accordance with HAULOTTE® recommendations and local regulations.

All malfunctions and problems identified during the inspection shall be corrected before the aerial work platform is returned to service.

1.2 - EMPLOYER'S RESPONSIBILITY

The employer (or plant superintendent) is required :

- To train and check the training of users.
- To authorise the trained user(s) to use the machine.
- To inform and familiarize the operator with the local regulations.
- Forbid anyone from operating the machine if :
 - Under the influence of drugs, alcohol, etc.
 - Subject to fits, convulsions, dizziness, etc.

1.3 - TRAINER'S RESPONSIBILITY

- The trainer must be qualified to provide training to operators in accordance with applicable local regulations.
- The training must include all of the instructions in this manual.
- The training must be given in an obstacle-free area until the trainee is considered competent as defined by the training program undertaken.

A - Foreword

1.4 - OPERATOR'S RESPONSIBILITY

The operator has the obligation to :

- Read and understand the contents of this manual and familiarize himself/herself with the decals affixed on the machine.
- To inspect the machine before use according to HAULOTTE®'s recommendations..
- Inform the owner (or hirer) if the manual or any decals are missing or are not legible.
- Inform the owner (or hirer) of any machine malfunction.

Operators must ensure that the inspections have been carried out by the owner and that they can use the machine for the purpose intended by the manufacturer.



All users (driver, passenger, maintainer, transporter, etc.) must familiarise themselves with the emergency controls and machine operation in case of an emergency.

The operator has the obligation to stop using the machine in the event of malfunction or safety problems on the machine or in the work area and report the problem immediately to his/her supervisor.

A

B

C

D

E

F

G

H

I

A - Foreword

2 - Safety

2.1 - SAFETY INSTRUCTIONS

2.1.1 - Incorrect use

- Do not use the machine outside of the conditions specified in this manual.
- Do not use the machine as a crane, material lift or elevator.
- Do not use the work platform as a hoisting machine (crane) by suspending a load outside of the platform.
- Do not tie the platform to an adjacent fixed or mobile structure.
- Do not use/operate the machine when alone. A survey person or immediate Supervisor must be present on the ground in case of emergency.
- Do not use a faulty or poorly maintained machine. Remove defective/damaged machine from service.
- Do not climb onto the compartment covers of the machine.
- Do not replace items critical to machine stability with items of different weight or specification.
- Do not replace the wheels installed in the factory with wheels with different characteristics.
- Do not alter or disable machine components that in any way affect safety and stability.
- Do not disable the safety devices.
- Do not use the machine if a label is missing or illegible.
- Do not damage, modify or hide machine labels or inscriptions.



A - Foreword

2.1.2 - Falling Hazards

N.B.:-THE GUARDRAIL IS THE MAIN PROTECTION SYSTEM AGAINST FALLS FROM THE MOBILE LIFTING PLATFORM (PEMP).

Before commencing operation :

- Ensure that guard rails are correctly installed and secured.
- Ensure that gate or sliding bar is in its securely locked position.
- If using a machine that has a swing gate, check that the entry gate closes by itself and gate latches and locks.



- Remove oil or grease from the steps, floor, handrail and the guardrails.
- Clean the floor of the platform (no debris).

To enter or exit from the platform :

- The machine must be completely stowed (Access configuration).
- Face the machine to access the opening to the platform.
- Keep 3 points of contact (both hands and a foot) on the steps and the guardrail.
- Keep fingers away from moving parts near entry gate.



When in the platform :

- Where personal fall protection equipment (FPE) is required by the employer, a competent authority or local regulations, we recommend using a full harness with a safety line.
- Personal fall protection equipment must only be fastened to approved fall protection anchoring points on the platform provided for this purpose.
- Refer to this decal located on the platform.
- Safety lines must never be attached to an object or structure outside of the work platform.
- Hold on securely to the guardrails.

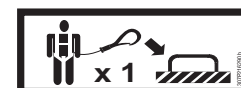

- Always keep your feet firmly on the floor of the platform.
- Do not sit, stand, or climb on the platform guard rails.
- Do not lean on the gate or sliding bar.
- Do not lean over the guard rails or climb over them. Only work in the platform area within the guard rails.
- Do not exit the platform until it is in the completely stowed position.
- Do not use the guardrail as a means of access to climb in or out of the platform.



A - Foreword

2.1.3 - Overturning / Tip-over Hazards

Before positioning and operating the machine :

- Ensure that the surface is capable of supporting the machine weight including the rated capacity.
- Do not exceed the maximum rated capacity that includes the weight of both material and allowed number of occupants. Do not exceed the allowable number of occupants.
- Do not increase the working height (using extensions, ladder, etc.).
- Do not place ladders or scaffolds in the platform or against any part of this machine.
- Position loads uniformly in the centre of the work platform.
- Do not use the machine at wind speeds that are above the permissible threshold. Refer to the display on the work platform to view the permissible wind speed.
- Do not increase the surface area of the platform exposed to wind. This includes adding panels, mesh, banners. Failure to follow this instruction may lead to a loss of stability and as a result, the machine could tip over.
- Do not raise the platform or move the machine with the platform raised on a slope with a gradient greater than the machine's permissible limit.
- Do not drive the machine on slopes or grades exceeding the specified limits.
- Do not pull or push towards any object outside of the platform. Do not exceed the maximum allowable side force stated in the performance specifications.
- Do not use the machine to support any external structure.
- Do not use the machine to tow other machines or to drag materials.



A- Foreword

- Using the machine on a slope

By slope is meant the tilt of a surface in relation to the horizontal plane.

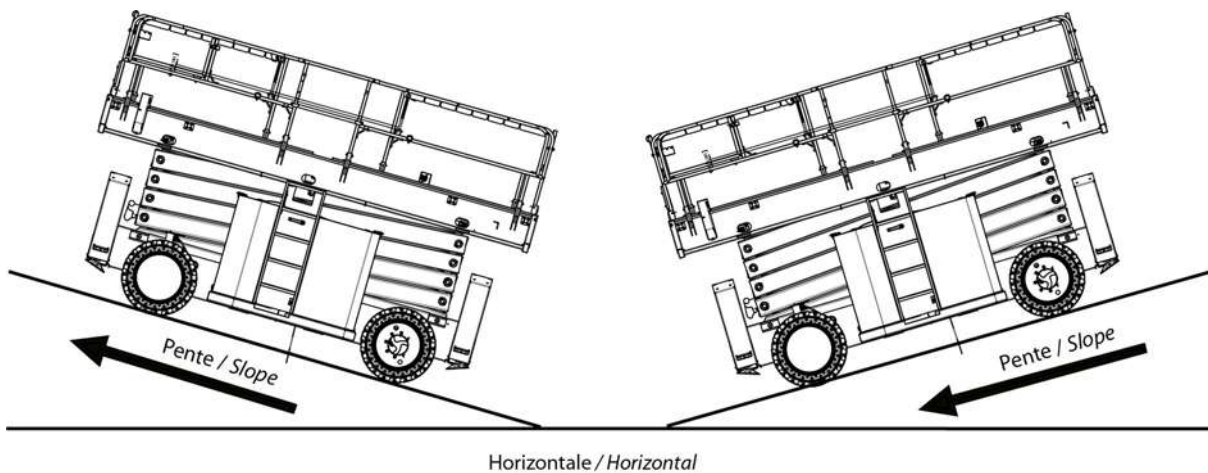

Do not drive the machine on slopes with gradients exceeding the authorised limit for the machine.
 Section B 4.1 - Technical specifications.



While driving on a slope :

- Always orientate the machine in the direction of the slope.
- Stow the machine completely.
- Do not travel down slopes in high speed.



- Do not make a U turn on the slope.

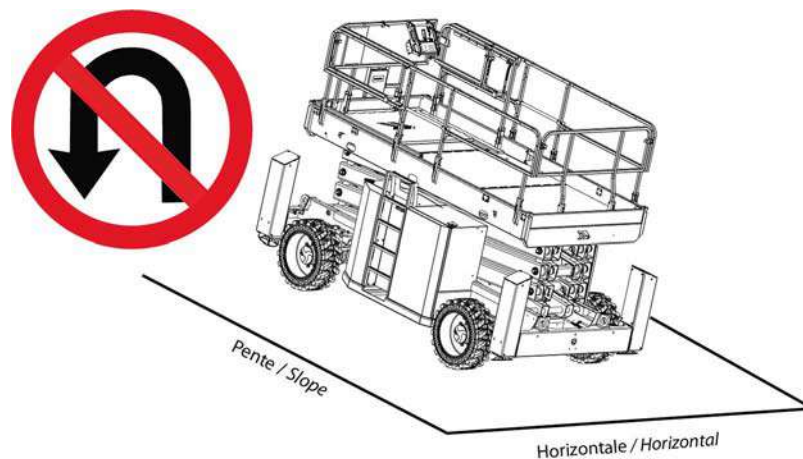

A - Foreword



- Do not drive diagonally or sideways on a slope.



WIND: the aerial work platform can be used up to the maximum wind speed indicated in the specifications in this manual. To identify the local wind speed, use the Beaufort scale below, a wind gauge or an anemometer.

N.B.-:-THE BEAUFORT SCALE OF WIND FORCE IS ACCEPTED INTERNATIONALLY AND IS USED WHEN COMMUNICATING WEATHER CONDITIONS. A WIND SPEED RANGE AT 10 M (32 FT 9 IN) ABOVE FLAT, CLEAR LAND IS ASSOCIATED WITH EACH DEGREE.

Beaufort scale

Force	Meteorological description	Observed effects	m/s	km/h	mph
0	Calm	Smoke rises vertically.	0 - 0,2	0 - 1	0 - 0,62
1	Very light breeze	Smoke indicates the wind direction.	0,3 - 1,5	1 - 5	0,62 - 3,11
2	Light breeze	Wind felt on the face. Leaves rustle. Weather vanes turn.	1,6 - 3,3	6 - 11	3,72 - 6,84
3	Slight breeze	Leaves and small twigs in constant motion. Flags move slightly.	3,4 - 5,4	12 - 19	7,46 - 11,8
4	Nice breeze	Raised dust and loose papers. Small branches are moved.	5,5 - 7,9	20 - 28	12,43 - 17,4
5	Nice breeze	Small trees in leaf to sway. Crested wavelets form on inland waterways.	8,0 - 10,7	29 - 38	18,02 - 23,6
6	Cool wind	Large branches in motion. Power lines and chimneys 'sing'. Umbrellas used with difficulty.	10,8 - 13,8	39 - 49	24,23 - 30,45
7	Near gale	Whole trees in motion. Inconvenience felt when walking against wind.	13,9 - 17,1	50 - 61	31 - 37,9
8	Gale	Some branches break. Generally we cannot walk against the wind.	17,2 - 20,7	62 - 74	38,53 - 45,98
9	Strong gale	The wind causes slight damage to buildings. Tiles and chimney stacks are blown off.	20,8 - 24,4	75 - 88	46,60 - 54,68

A - Foreword

2.1.4 - Risk of electric shock (electrocution)



Risk of death or serious injuries

The machine is not electrically insulated and does not provide protection from contact or proximity to electrically charged conductors.

Always position all parts of the aerial work platform, the occupants, accessories and tools at a reasonable distance from power lines to ensure that no part of the work platform accidentally comes into contact with a power line.

Apply local regulations pertaining to safety distances. If this is not possible, follow the distances in the table below at a minimum :

Minimum safe approach distances

Electric voltage	Minimum safety distance	
	Mètre	Feet
0 - 300 V	Avoid contact	
300 V - 50 kV	3	10
50 - 200 kV	5	15
200 - 350 kV	6	20
350 - 500 kV	8	25
500 - 750 kV	11	35
750 - 1000 kV	14	45

- Do not operate the machine when close to live power lines, consider the movement of the machine and the sway of the electric power lines particularly in windy conditions.
- Do not operate the machine during lightning, thunderstorms, snow/ice or any weather condition that could compromise operator safety.
- The machine must not be used while charging the batteries.
- When using the platform AC power supply, ensure it is protected with a circuit breaker and residual current device.
- Do not use the machine as a ground for welding.
- Do not weld on the machine without first disconnecting the battery terminals.
- Always disconnect ground cable first.



Keep away from the machine if it contacts energized power lines. Personnel on the ground or in the platform must not touch or operate the machine until energized power lines are shut off.



A - Foreword

2.1.5 - Explosion / Fire Hazards

- Always wear protective clothing and eye wear when working with batteries and power sources/systems.

N.B.:-ACID IS NEUTRALIZED WITH SODIUM BICARBONATE AND WATER.

- Do not start the engine if you smell or detect liquid propane gas (LPG), gasoline, diesel fuel or other explosive substances.



Do not work on or operate a machine in an explosive or flammable atmosphere / environment.

- Do not touch hot components.
- Do not bridge the battery terminals with metallic objects.
- Do not service the battery in proximity of spark, open flame, lit cigarettes.
- Do not fill up the fuel tank, when the engine is running and/or near a flame.



2.1.6 - Crushing / Collision Hazards



Before using the machine, mark out the machine's work and circulation area using a marking system appropriate to the task at hand and the work environment.

When in the platform :

- Check the work area for overhead clearance, for any obstacles besides and below the platform when raising/lowering the platform and or before driving.
- During movement, keep all the parts of the body inside the platform. Hold onto the guardrails on the opposite side to any surrounding structures. Take care to avoid trapping hands whilst holding the guardrails.
- To position machine close to a building/structure, use extension deck feature, instead of driving machine closer to structure.
- Warn personnel not to work, stand, or walk under a raised boom/platform.
- Always ensure that the chassis is never kept any closer than 1 m (3 ft 3 in) to holes, bumps, slopes, obstructions, debris and ground coverings that may hide holes and other dangers.



A

B

C

D

E

F

G

H

I

A- Foreword

- Keep non-operating personnel at least 5 m (16 ft 5 in) away from the machine when driving.
- Be aware of driving direction.
 - Check the driving direction with the help of the red or white arrows on the chassis and the platform control box.
 - Also note that when changing the driving direction (Forward <> Reverse) the joysticks or switches must return to the neutral position before reversing the drive direction and for movement to occur.
- When driving, position the platform so as to provide the best possible visibility and to avoid any blind spots.
- Hold on securely to the guardrails.
- Personal Protection Equipment (EPI) :
 - The occupants of the aerial work platform must wear personal protection equipment and comply with local regulations in force.
 - Operators must comply with the safety standards of the job site and the employer, as well as the applicable state regulations relating to the use of personal protective equipment.
 - All personal fall protection equipment (PFPE) must comply with current regulations, must be inspected and used in accordance with the manufacturer's instructions.
- Avoid contact with fixed or mobile obstacles (other machines).
- Other machines (crane, aerial work platform, etc.) operating in the work area increase the risk of crushing or collision. Restrict the operation of machines moving within the aerial work platform work area.
- Take into consideration the stopping distance, reduced visibility and blind spots of the machine.
- Limit travel speed to suit the ground surface condition, slope (incline), and people in the vicinity.

2.1.7 - Risk of involuntary movements

Never use a damaged or malfunctioning machine.

Always respect the following rules :

- Maintain clearance from high voltage lines.
- Maintain clearance from generators, radar, electromagnetic fields.
- Never expose the batteries or electrical components to water (high pressure washer, rain).

A - Foreword

3 - Safety inquiries

Inquiries relating to design criteria/specifications of a product, standards compliance, or overall machine safety should be sent to the HAULOTTE® PRODUCT SAFETY department.

Each inquiry or request should include all relevant information; including contact name, telephone number, mailing address, email address, plus the machine model and serial number.

The HAULOTTE® Product Safety department will evaluate each request/inquiry and will provide a written response.

4 - Incident notification

Notify HAULOTTE® immediately when a HAULOTTE® product has been involved in an incident/accident leading to personal injury or death, or when there is a major property damage.

<p>HAULOTTE Group - EUROPE Product Safety Department</p> <p>Address : Rue Emile Zola - 42420 Lorette - France</p> <p>Tel : +33 (0)4 77 29 24 24</p> <p>Email : productsafety.europe@haulotte.com</p>	<p>HAULOTTE Group - Australia, India and Asia Product Safety Department</p> <p>Address : No.26 Changi North Way - Singapore 498812 - Singapore</p> <p>Tel : +65 6546 0123</p> <p>Email : productysafety.apac@haulotte.com</p>	<p>HAULOTTE Group - North & South America Product Safety Department</p> <p>Address : 3409 Chandler Creek Rd. - Virginia Beach, VA 23453 - United States</p> <p>Tel : +1 757 689 2146</p> <p>Email : productsafety.americas@haulotte.com</p>
--	---	---

Connect to our website : www.haulotte.com



A - Foreword

5 - Compliance

5.1 - PRODUCT MODIFICATION

It is strictly forbidden to modify a HAULOTTE® product. Any modification may violate Haulotte design parameters, local regulations and industry standards.

Any requests for modification must be formulated in writing (form) and be approved by the manufacturer.

Do not hesitate to contact HAULOTTE Services®, should you have any questions relating to the issued bulletin(s) or with questions on the policy itself.

5.1.1 - Implementing manufacturer safety campaigns

It is essential to implement the safety campaigns issued by the manufacturer. All of these campaigns are accessible on our website.

Connect to our website : www.haulotte.com



Never market (or sell) a machine without first having carried out all of the safety campaigns.

5.2 - PRODUCT SPECIFICATIONS

HAULOTTE® cannot be held liable for any changes to the technical characteristics/ specifications contained in this manual. HAULOTTE® has a continuous improvement policy in place for its product range. Given this policy, the Company reserves the right to modify products technical characteristics / specifications without notice.

A - Foreword

5.3 - CHANGE OF OWNERSHIP NOTIFICATION

It is important and necessary to keep HAULOTTE Services® updated with current ownership of the machine. This way, HAULOTTE® will be able to provide the necessary support for the product. If you have sold or transferred this machine(s); it is your responsibility to notify HAULOTTE Services®. It is not required to include Lessees/Renters of Leased/Rented machines on this form.

Connect to our website : www.haulotte.com



A

B

C

D

E

F

G

H

I

A - Foreword

5.4 - DECLARATION OF CONFORMITY



The CE declarations of conformity only apply to machines that have been approved and commissioned within the European Community (EC).

Declaration of conformity - Electric platforms



**DECLARATION CE DE CONFORMITE
(EC DECLARATION OF CONFORMITY)**



<p>Fabricant et personne autorisée à constituer le dossier technique : <i>(Manufacturer and the person authorised to compile the technical file:)</i></p> <p>HAULOTTE GROUP</p> <p>Adresse du site de production <i>(Address of the Division)</i></p> <p>en conformité avec le modèle type <i>(In compliance with the Model Type)</i></p> <p>Nom commercial <i>(Commercial name)</i></p> <p>Numéro de série <i>(Serial number)</i></p> <p>Organisme notifié <i>(Notified body)</i></p> <p>Numéro de certificat <i>(Certificate number)</i></p> <p>Charge maximale d'utilisation <i>(Rated capacity)</i></p>	<p>Compliance & Regulation Director HAULOTTE GROUP S.A. RUE EMILE ZOLA 42420 LORETTE FRANCE</p> <p>Nacelle élévatrice de personnel <i>(Mobile Elevating Work Platform)</i></p> <p>Modèle type de la machine concernée <i>(Type model of the concerned machine)</i></p> <p>Nom commercial de la machine concernée <i>(Commercial name of the concerned machine)</i></p> <p>Numéro de série de la machine <i>(Serial number of the machine)</i></p> <p>Nom et adresse de l'organisme notifié <i>(Name and address of notified body)</i></p> <p>Numéro de certificat du type de machine <i>(Certificate number of the type of machine)</i></p> <p>Charge maximale d'utilisation de la machine concernée <i>(Rated capacity of the concerned machine)</i></p>
--	---

Nous déclarons que cette machine est conforme aux dispositions des Directives suivantes
 (We hereby declare that this machine conforms with all the relevant provisions of the Directives listed below)

Directive CE Machine <i>(EC Machinery Directive)</i>	2006/42/CE
Se conforme aux principales exigences de la norme harmonisée <i>(This machine also fulfils the principles of the harmonised standard)</i>	EN280:2013 + A1:2015
Directive CE concernant la compatibilité électromagnétique <i>(EC Directive on electromagnetic compatibility)</i>	2014/30/EU
Directive CE RED concernant les équipements radioélectriques (si machine équipée) <i>(RED EC Directive on radio electrical equipment (if machine equipped))</i>	2014/53/UE

Cette déclaration porte exclusivement sur la machine dans l'état où elle a été placée sur le marché
(This declaration relates exclusively to the machinery in the state in which it was placed on the market)

Toute modification de la machine décrite ci-dessus a pour effet d'invalider cette déclaration
(Any modification to the above described machine violates the validity of this declaration)

Nom et signature du Directeur du site de production <i>(Name and signature of the Division Director)</i>	Lieu (Place)
	Date (Date)

haulotte.com

A - Foreword



UKCA Declarations of Conformity only apply to machines that are certified for England, Wales and Scotland.

Declaration of conformity - Electric platforms

UKCA DECLARATION OF CONFORMITY

Manufacturer and the person authorised to compile the technical file:
HAULOTTE GROUP

France

Certificate number
 Rated Capacity

Nathalie Reynolds
 General Manager UK and Ireland
 Haulotte UK Ltd

Unit 1 Gravelly Way, Four Ashes
 Wolverhampton, West Midlands WV10 7GW
 ENGLAND

Mobile Elevating Work Platform

In compliance with the Model Type	<i>Model Type of the concerned machine</i>
Commercial name	<i>Commercial name of the concerned machine</i>
Serial number	<i>Serial number of the machine</i>
Approved body	
Certificate number	
Rated Capacity	<i>Rated capacity of the concerned machine</i>

We hereby declare that this machine conforms with all the relevant provisions of the Regulations listed below

Supply of Machinery (safety)	2008
This machine also fulfils the principles of the designed standards	
Electromagnetic compatibility	2016
Radio equipment (if machinery equipped)	2017

This declaration relates exclusively to the machinery in the state in which it was placed on the market
 Any modification to the above described machine violates the validity of this declaration

Name and signature division director

Date and place

haulotte.com

B - Familiarization

1 - General safety

1.1 - INTENDED USE

Do not operate the product in the following situations :

- On soft, unstable or cluttered ground.
- With wind blowing faster than the permissible limit :
 - Check the allowable wind speed specified in the performance specifications tabulation.
 - Consult the Beaufort scale.
- Close to power lines. Keep a safe distance.
- If the machine is stored at a temperature out of range - 20°C / + 50°C (- 4°F / + 122°F).
- In an explosive atmosphere / environment.
- During storms.
- In the presence of strong electromagnetic fields.

N.B.-:USE THE MACHINE UNDER "NORMAL" CLIMATIC CONDITIONS. IF YOU NEED TO USE THE MACHINE IN CLIMATIC CONDITIONS LIKELY TO CAUSE DETERIORATION (EXTREME : HUMIDITY, TEMPERATURES, SALINITY, CORROSIVENESS, ATMOSPHERIC PRESSURE), CONTACT HAULOTTE SERVICES®. REDUCE INTERVALS BETWEEN SERVICING.

N.B.-:WHILE THE MACHINE IS NOT IN USE, CARE MUST BE TAKEN TO BRING THE MACHINE TO THE FULLY STOWED POSITION. ENSURE THAT THE MACHINE IS LOCKED IN A SECURE LOCATION, AND THE CONTROL KEY IS REMOVED TO PREVENT UNAUTHORISED USE OF THE MACHINE.

B- Familiarization

1.2 - DECAL CONTENT

The purpose of the labels on the machine is to alert the user to the conditions of use and risks related to aerial work platforms.

Decals provide the following information :

- The level of severity.
- The specific hazard.
- A method to avoid, suppress or reduce the hazard.
- Descriptive text (where required).

Familiarize yourself with the decals and the hazard severity levels.

The labels must be kept in good condition, otherwise they must be replaced.

Familiarize yourself with the decals and their respective color codes.

Additional decals can be ordered from HAULOTTE Services®.

**C E , U K C A , A S and E A C standards - Label
warning risk**



Marking	Description
1	Risk identification symbol
2	Avoidance symbol pictorial

B- Familiarization

CE, UKCA, AS and EAC standards - Label informing about an important function of the machine

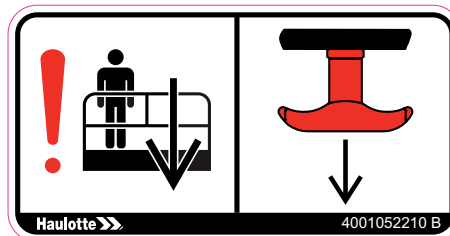

ANSI and CSA standards









Marking	Description
1	Risk identification symbol
2	Level of severity
3	Avoidance symbol pictorial
4	Avoidance text

B- Familiarization











1.3 - SYMBOLS AND COLORS

Symbols and colors are used to alert the operator of safety precautions and/or to highlight important safety information.

The following safety symbols are used throughout this manual to indicate specific hazards and the hazard severity level when operating or maintaining the Aerial Work Platform.

Symbol	Description
	Danger : Risk of injury or death
	Caution : Risk of material damage
	Prohibited action
	Reminder to use good practice or follow pre-operation checks
	Cross-reference to another part of the manual
	Cross-reference to another manual
	Cross-reference to repair (contact HAULOTTE Services®)
N.B. :	Additional technical information

1.4 - LEVEL OF SEVERITY

Color	Title	Description
		Danger : Indicates a hazardous situation which if not avoided, WILL result in death or serious injury.
		Warning : Indicates a hazardous situation which if not avoided, COULD result in death or serious injury.
		Caution : Failure to comply could result in minor or moderate injury.
		Notice : Indicates recommended practices if not followed, may result in a malfunction or damage the machine or its components.
		Procedure : Indicates a maintenance operation.

B- Familiarization

1.5 - SYMBOLS LEGEND AND DEFINITIONS

Symbols are used throughout this manual to depict hazards, avoidance measures and indicate when information is required.

Refer to the following table to familiarize yourself with these symbols.

Symbo 	Description	Symbo 	Description	Symbo 	Description
	Risk of crushing or pinning		Foot crushing hazard		High pressure fluid ejection hazard
			Hand crushing hazard		Crushing hazard
			Health/safety hazards related to chemicals		Burn hazard
	Risk of electrocution		Burns and scalds from contact with flames, explosion or radiation from heat sources		Injury from Electric arcs - Energy supply disconnecting devices - Batteries fire, emissions, etc
	Fall hazard		Tip over due to excessive loading / wind load and excessive ground slope		Relate and coordinate directional arrows on the chassis with those on the control box
	Do not put foot in this area		Do not put your hand in this area		Keep away from product working area
	Use of high-pressure cleaners prohibited		Ensure entry drop rail is down		
	Flames prohibited		Maintain safe clearance from high voltage electrically charged conductors as described in manual - Do not use in thunderstorms		Overload
	Refer to operator manual		Safety belt		Use appropriate lanyard attached to dedicated anchor point.
	Wheel pressure		Enable switch		Use safety prop before attempting any maintenance work
	Tow point		Tie down point		Lift point
	Keep away from hot surfaces		Wear protective equipment		

B - Familiarization

2 - Models description

Models	Regulations						
	CE	UKCA	ANSI	CSA	EAC	AS	JIS
HS15 E	✓	✓	✗	✗	✓	✓	✓
HS15 E PRO	✓	✓	✗	✗	✓	✓	✓
HS18 E	✓	✓	✗	✗	✓	✓	✓
HS18 E PRO	✓	✓	✗	✗	✓	✓	✓
HS4390 E	✗	✗	✓	✓	✗	✗	✗
HS4390 E PRO	✗	✗	✓	✓	✗	✗	✗
HS5390 E	✗	✗	✓	✓	✗	✗	✗
HS5390 E PRO	✗	✗	✓	✓	✗	✗	✗

Legend

✓	Available
✗	Not available

B - Familiarization

3 - Primary machine components

3.1 - LAYOUT

HS15 E (HS4390 E) - HS15 E PRO (HS4390 E PRO) - HS18 E (HS5390 E) - HS18 E PRO (HS5390 E PRO)

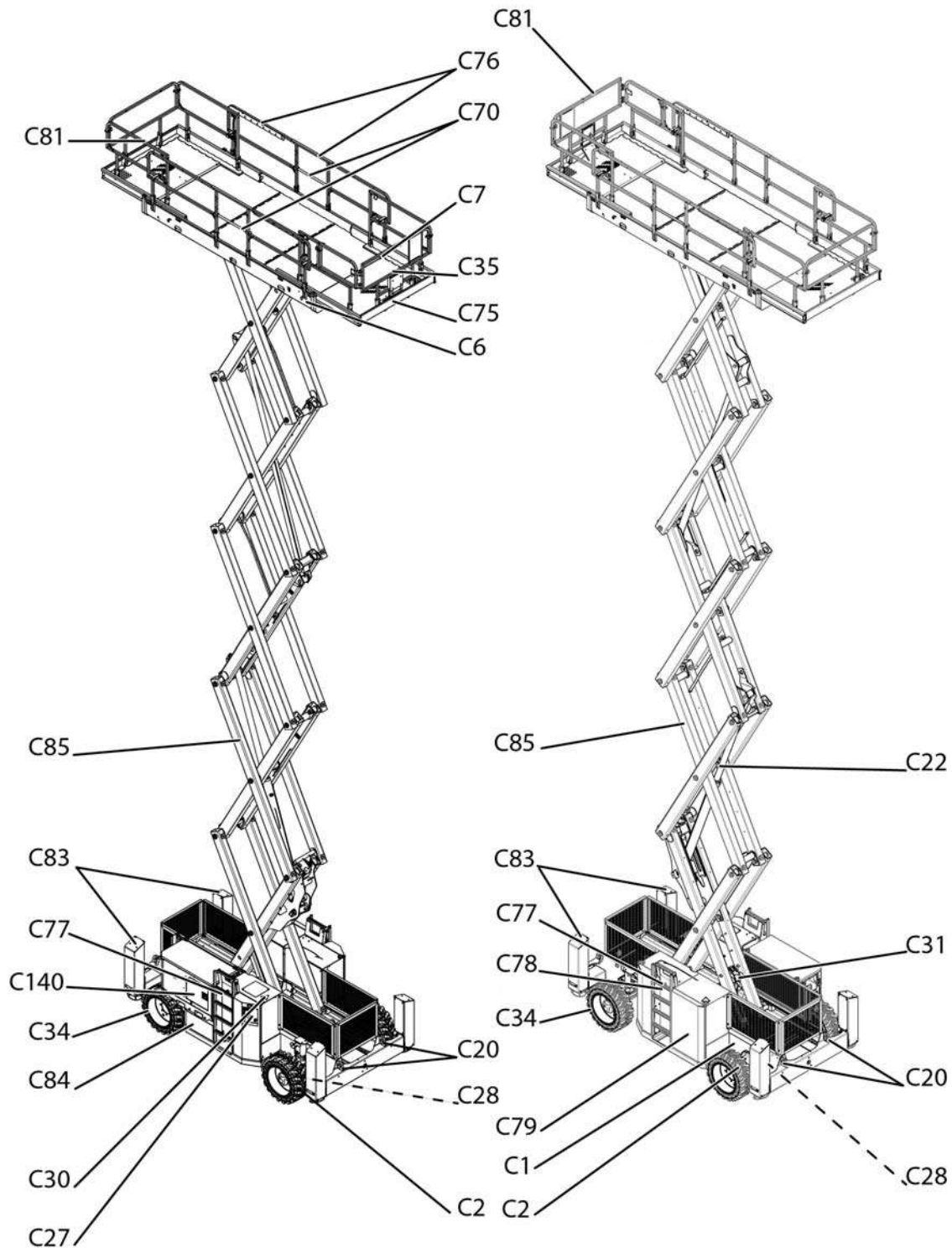

B- Familiarization

Marking	Description	Marking	Description
C1	Chassis	C70	Platform access bar
C2	Front driven steering axle	C75	Platform extensions (if equipped)
C6	Platform	C76	Guardrail
C7	Platform control box	C77	Platform access ladder
C20	Anchorage point	C78	Hood locking catch
C22	Scissors lifting cylinder	C79	Battery box
C27	Ground control box + Universal plug	C81	Sliding guardrail
C28	Tilt sensor	C83	Stabiliser
C30	Hydraulic oil tank	C84	Hydraulic circuit
C31	Maintenance support	C85	Scissors
C34	Drive wheels	C140	Range Extender (If equipped)
C35	Document holder		

Universal plug connection

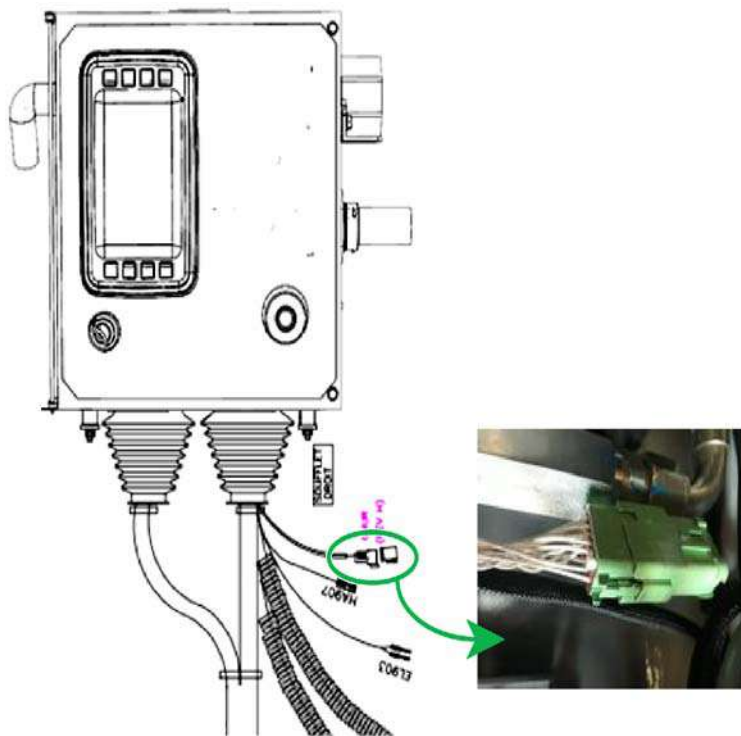

B- Familiarization

3.2 - MAINTENANCE SUPPORT



The maintenance prop must be in place before any maintenance operation of the arm is begun.



Placing the machine in operational configuration (Maintenance use) :

- Lift scissor arms to a sufficient height to tilt the stand.
- Tilt the stand to the vertical position. A mechanical locking click sound occurs.
- The stand should remain in the vertical position.
- Lower the scissor arms.
- Scissor arm pivoting rod should rest on the V groove of the stand.



B- Familiarization

Placing the machine in the operational position (Excluding maintenance) :

- Lift scissor arms to a sufficient height to tilt the stand.
- Press the unlocking button on the maintenance stand .
- Tilt the stand to the horizontal position.
- Lower the scissor arms.

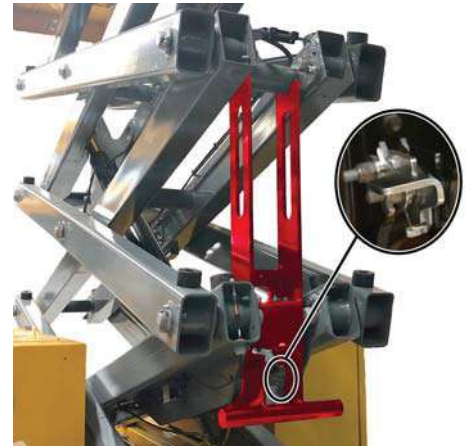

A

B

C

D

E

F

G

H

I

B - Familiarization



3.3 - GROUND CONTROL BOX

3.3.1 - Layout

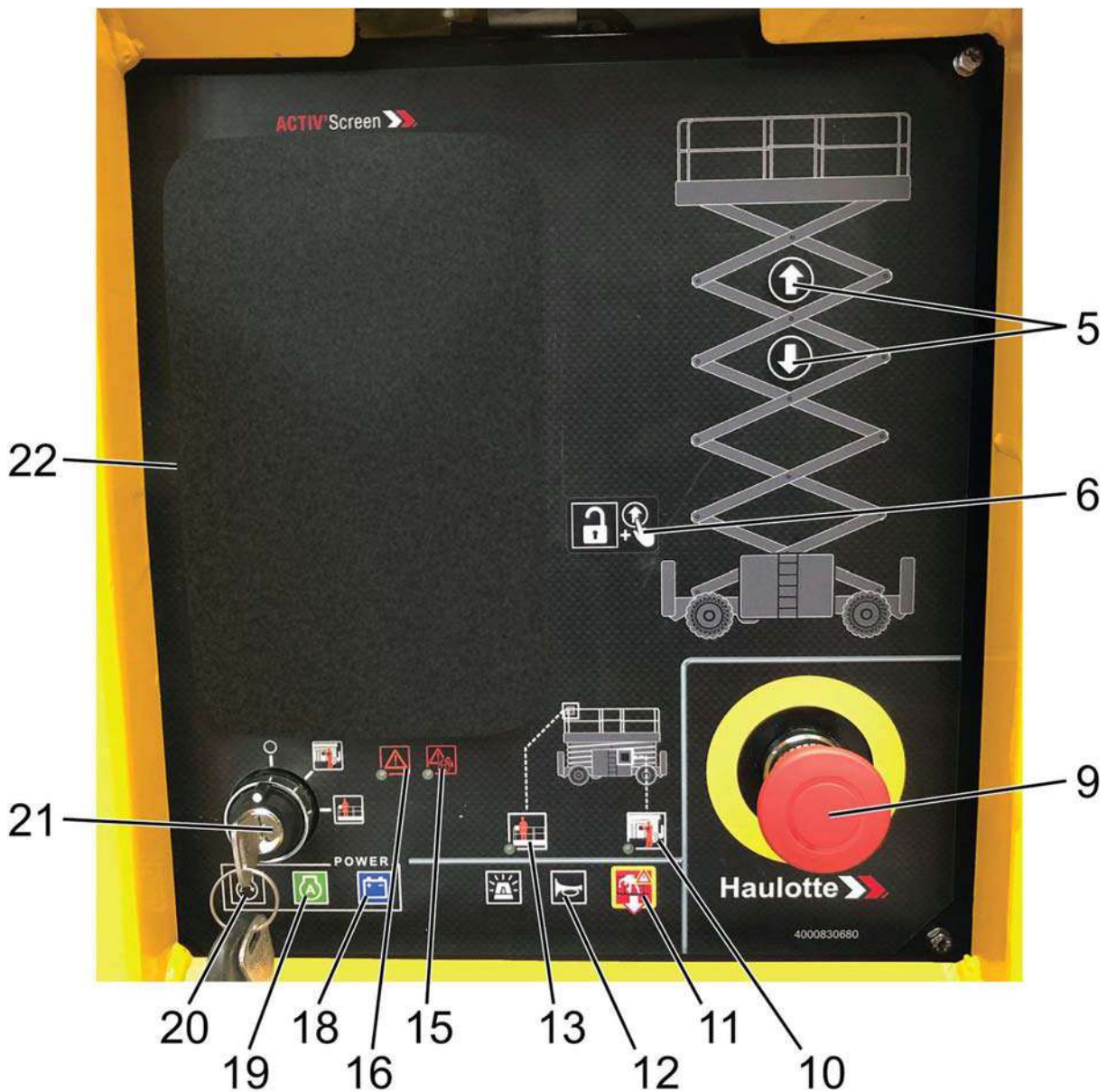





General view - Monochrome LCD display







Controls and indicators

Marking	Name	Description	Function
5	SA420	Platform raising / lowering selector	By pressing on  : Platform lift.
			By pressing on  : Platform descent.

B- Familiarization

Marking	Name	Description	Function
6	SA905EN	Enable Switch	By pressing on Enable Switch  and simultaneously a desired function will activate a movement.
9	SB801	E-stop button	Pulled out : Ground control box energized. Pushed in (activated) : De-energizes control system.
10	HL905	Indicator, ground control box selected	LED lights up - ground control box icon.
11	SA801	"Overriding system" control	By pressing on  : Authorize movements from the ground control box in case of overload (Use ONLY in case of emergency).
12	SB907	Horn button	By pressing on  : Horn activation.
13	HL906	Indicator of the platform control box selection	LED lights up - platform control box icon.
15	HL908	Overload indicator	Alarm icon  : <ul style="list-style-type: none"> Flashes when the machine starts at the same time as the (16) icon Is blinking if overriding is active : If a fault is detected, an error code is displayed on the on-board screen Or Hydraulic oil temperature icon is active on on-board screen Or the engine pressure icon is displayed on the on-board screen Or the engine stop icon is displayed on the on-board screen Or the machine overload icon is displayed on the on-board screen
16	HL909	Engine warning indicator / Engine pre-heating	Alarm icon  : <ul style="list-style-type: none"> Flashes when the machine starts at the same time as the (15) icon Is blinking if overriding is active Warning icon is ON if : Engine warning icon is active on on-board screen Or the machine tilt icon is displayed on the on-board screen Or Engine is pre-heating
18	SA308	Full Electric mode (If equipped with the Range Extender option)	In Full Electric mode, the combustion engine never starts. Energy comes from the batteries. This mode  is activated by default when starting the machine.
19	SA309	Auto mode (If equipped with the Range Extender option) Refer to operator manual-  Section D 1.5 - Mode operation	In Auto Mode  , the combustion engine starts and stops depending on the machine's use and traction battery charge level. The combustion engine recharges the batteries.

B- Familiarization











Marking	Name	Description	Function
20	SA905	Manual mode (Forced charging) (If equipped with the Range Extender option) Refer to operator manual-  Section D 1.5 - Mode operation	In Manual Mode  , the user starts and stops the combustion engine. The combustion engine recharges the batteries. Above 100 %, the engine stops if no movement is initiated.
21	SA900	Control box activation key switch	 : De-energizes control system.
			 : Platform control box energized.
			 : Ground control box energized.
22		Monochrome LCD display	

B- Familiarization









3.3.2 - Display Panel (LED'S 1 - 10) - Monochrome LCD display

Display



Marking	Symbol	Description
LED 1		Overriding system : • Remains on if the Overriding (11) system command is activated
LED 2		Fault : • Rapid flashing if a fault is active (current defect) • Rapid flashing if an alarm code is activated (From A03 to A07) • Flashing if the service counter is at zero
LED 3		Not used
LED 4		Overload • Flashing : Faulty weighing system • Flashing if overloaded
LED 5		Combustion engine pre-heating : • Illuminated while engine is pre-heating • Off if engine started and if post-heating
LED 6		Low water level tank : • Refill the water battery tank with demineralized water
LED 7		Battery level low : • Recharge batteries
LED 8		35 hours without full recharge : • Warning next recharge must be a full recharge by plugging the machine electrical socket to external source of power
LED 9		Energizes control system • ON : Machine switched on • OFF : Machine switched off
LED 10		Thermal engine start-up • ON : Engine started • OFF : Engine switched off

B- Familiarization

Symbol	Description
	Illuminated when service counter is displayed
	<ul style="list-style-type: none"> • Illuminated when engine is not running or when hour meter is displayed • Flashing engine in operation
	Low fuel level
	<ul style="list-style-type: none"> • OFF : Batteries not charging • Flashing : Batteries charging • ON : Batteries fully charged and machine connected
	<p>Display of service counter for 3 s when the machine is switched on, then display of the hour meter for 3 s.</p> <p>Then</p> <ul style="list-style-type: none"> • Display of one or more faults, if present, with scrolling of faults every 2 s • Display of service counter if it is at zero • Display of hour meter
	Indicates the engine speed
	<ul style="list-style-type: none"> • Indicates engine temperature, if available on the engine • All the bars flash if engine overheating
	Indicates the level of charge in the battery from 0 % to 100 %

A

B

C

D

E

F

G

H

I









B- Familiarization

Fault and alarm codes

Failures codes			
Failure code F01.xx	Fault - Variator	Failure code F09.xx	Fault - IC Engine
Failure code F02.xx	Fault - power contactor	Failure code F10.xx	Fault - Functions
Failure code F03.xx	Fault - command relay	Failure code F11.xx	Fault - machine safety
Failure code F04.xx	Fault - electro-valve	Failure code F12.xx	Fault - electronic control unit ECU
Failure code F05.xx	Fault - joystick	Failure code F13.xx	Fault - Switches
Failure code F06.xx	Fault - weight management system	Failure code F14.xx	Fault - Driving pump
Failure code F07.xx	Fault - limit switch or sensor	Failure code F15.xx	Fault - data communication system CAN
Failure code F08.xx	Fault - electrical circuit	Failure code F16.xx	Fault - Electric motor

B- Familiarization

Alarm codes

A03		Tilt	The machine is elevated , and is on a slope greater than the permitted slope. Depending on the machine configuration, the lifting and extension functions are slowed or stopped.
A04		Activ' Shield Bar disable	The secondary safety system is switched off.
A05		Activ' Shield Bar triggered	<p>The secondary safety system is triggered. An operator may be trapped on the platform :</p> <ul style="list-style-type: none"> • In this situation, supervisor(s) at ground level must turn the control box key selector (22) to the ground control box  position to take control. • The platform box controls are now de-energizedThe platform box controls are now de-energized. • Check that the E-Stop button (9) at ground is not pressed in. • To safely activate movements from the ground control box, the Enable Switch (6)  must be pressed and held.
A06		Emergency mode is activated when : <ul style="list-style-type: none"> • The E-Stop at platform control box is pushed in (de-energized). • The machine is in overload state. • Ground control box is selected/energized. • The emergency overriding button is activated. 	
A07		Emergency mode not active	This is for emergency use. Only active when the load detection system is on.
A07		Emergency mode not available	Emergency Mode is not operational. Rescue of platform may not be possible.

N.B.-:IF SEVERAL ALARM CODES ARE ACTIVE, THEY SCROLL SEQUENTIALLY EVERY 3 SECONDS ON THE DISPLAY. CODES A05 AND A06 TAKE PRIORITY OVER THE OTHER ALARM CODES, AND IN THIS CASE, ONLY THE PRIORITY CODE REMAINS ON THE DISPLAY. CODE A06 TAKES PRIORITY OVER CODE A05 AND IN THIS CASE, ONLY CODE A06 REMAINS ON THE DISPLAY.

B - Familiarization

3.4 - PLATFORM CONTROL BOX

3.4.1 - Layout

General view - HS15 E (HS4390 E) - HS15 E PRO (HS4390 E PRO) - HS18 E (HS5390 E) - HS18 E PRO (HS5390 E PRO)

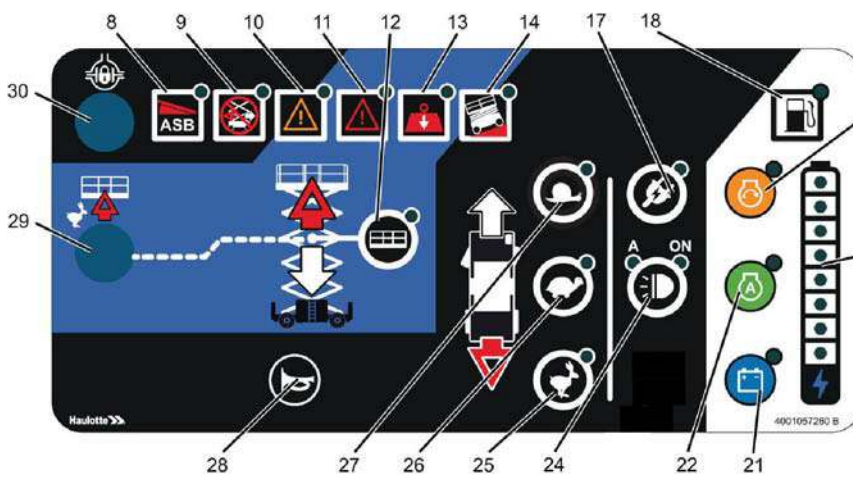
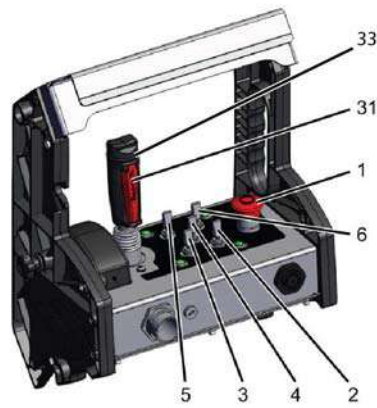
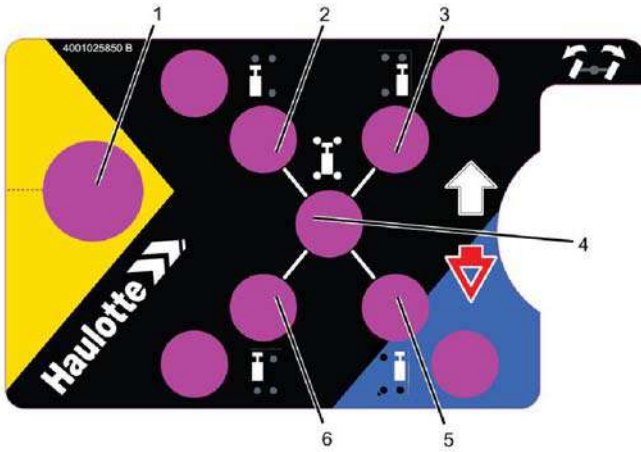







B- Familiarization

Controls and indicators

Marking	Name	Description	Function
1	SB802	E-stop button	<p>Pulled out : Platform control box power supply energized</p> <p>Pushed in : De-energizes control system</p>
2	SA121	Front left stabilizer extension/retraction selector	<p>Push the selector downwards to extend the stabilizers : Stabilizer extended and LED on (continuously: stabilizer extended and set against the ground; rapid flashing: stabilizer extended but not yet set; slow flashing: stabilizer totally extended but not set)</p> <p>Push the selector upwards to raise the stabilizers : Stabilizer retraction and corresponding LED off during lowering (Stabilizers retracted)</p>
3	SA124	Front right stabilizer extension/retraction selector	<p>Push the selector downwards to extend the stabilizers : Stabilizer extended and LED on (continuously: stabilizer extended and set against the ground; rapid flashing: stabilizer extended but not yet set; slow flashing: stabilizer totally extended but not set)</p> <p>Push the selector upwards to raise the stabilizers : Stabilizer retraction and corresponding LED off during lowering (Stabilizers retracted)</p>
4	SA120	Central stabilizer extension/retraction selector	<p>Push the selector downwards to extend the stabilizers : Stabilisers extended and LED lit (continuously: stabilizers extended and set against the ground; fast flashing: stabilizers extended but not yet set; slow flashing: stabilizers fully extended but not set)</p> <p>Push the selector upwards to raise the stabilizers : Stabilizer retraction and corresponding LED off when lowering (Stabilizers retracted)</p>
5	SA123	Rear right stabilizer extension/retraction	<p>Push the selector downwards to extend the stabilizers : Stabilizer extended and LED on (continuously: stabilizer extended and set against the ground; rapid flashing: stabilizer extended but not yet set; slow flashing: stabilizer totally extended but not set)</p> <p>Push the selector upwards to raise the stabilizers : Stabilizer retraction and corresponding LED off during lowering</p>
6	SA122	Rear left stabilizer extension/retraction selector	<p>Push the selector downwards to extend the stabilizers : Stabilizer extended and LED on (continuously: stabilizer extended and set against the ground; rapid flashing: stabilizer extended but not yet set; slow flashing: stabilizer totally extended but not set)</p> <p>Push the selector upwards to raise the stabilizers : Stabilizer retraction and corresponding LED off during lowering (Stabilizers retracted)</p>
8	HL901	Activ'Shield Bar Scissors Indicator (For machines equipped with it)	<ul style="list-style-type: none"> • Constantly on : Running movement. Activ'Shield Bar Scissors activated. • Off : Machine folded, backwards or forward drive. Activ'Shield Bar Scissors inactive. • Slow flashing : Machine folded, lifting movement selection, driving. Activ'Shield Bar Scissors activated
9	HL165	Driving cut-out indicator	Indicator on : Driving is forbidden
10	HL908	Range Extender preheating indicator light (For machines equipped with it)	<ul style="list-style-type: none"> • Constantly on : Preheating Range Extender • Flashing : Operation malfunction
11	HL903	Fault indicator	<ul style="list-style-type: none"> • Constantly on : Faulty weighing system — Overload • Flashing : Operation malfunction — Machine not set correctly — Cut-off 3 m lowering

B- Familiarization

12	HL420	Sensitive selector switch and indicator for basket (or platform) up/down control	Pressed down (activated and LED on) : Platform raising/lowering selection
13	HL802	Platform overload indicator	Illuminated when overloaded
14	HL800	Slope (tilt) indicator	On if the machine is in tilt
17	HL916	Generator selector (For machines equipped with it)	Pressed down (activated) : Platform supply
18	HL307	Fuel low level (For machines equipped with it)	On if the fuel level is low
19	HL314	Manual mode(Forced charging)	In Manual Mode  , the user starts and stops the combustion engine. The combustion engine recharges the batteries. At 100 %, the engine stops if no movement is commanded.
20	LBB01... LBB08	Battery level	Battery charging indicator
21	HL312	Full Electric mode	Energy comes from the batteries. This mode  is activated by default when starting the machine.
22	HL313	Auto mode	In Auto  mode, the Range Extender starts and stops depending on the machine's use and the battery's charging status. The range extender recharges the batteries.
24	HL911E	Activ' Lighting System selector	 ON
			 Automatic lighting
			 OFF
25	HL161	High-speed drive selector switch with indicator light	Pressed down (activated and LED on) : High-speed drive selection
26	HL162	Medium-drive speed selector switch and indicator	Pressed down (activated and LED on) : Medium speed drive selection
27	HL163	Low-speed drive selector switch with indicator light	Pressed down (activated and LED on) : Low-speed drive selection
28	SA907	Horn button	By pressing on  : Horn activation.
29	SB900	Activ'Shield Bar Scissors selector (If equipped)	Press in and hold (Activated) : Full speed lifting activation (if fitted)
30	SA100	Differential lock selector	Press in and hold : Differential blocking selection
31	SM901	Enable Switch	Press in and hold : Confirmation of the joystick movements
			Release : Associated command movement is halted

B- Familiarization

33	SM901	Drive joystick	Move forward (Push) : Forward drive(White forward arrow)
			Move backwards (Pull) : Reverse drive(Rear red drive direction arrow)
		Steering rocker switch	Press right side of button : Steer right
			Press left side of button : Steer left
		Lifting joystick	Move forward (Push) : Lowering
			Move backwards (Pull) : Lifting

A

B

C

D

E

F

G

H

I

B - Familiarization

4 - Performance Specifications

4.1 - TECHNICAL CHARACTERISTICS

Use the table to select the right Haulotte machine for the job.



Do not replace parts that are essential to the stability of the machine, such as batteries or tyres, with parts that have a different weight or different specifications. The stability of the machine could be affected.

CE, UKCA, AS, EAC, CSA and ANSI A92.20 standards

Machine	HS15 - HS4390	
	E	E PRO
Characteristics - Dimensions		
Total weight with standard platform + 1 extension	7 362 kg(16,230 lbs)	Not applicable
Total weight with standard platform + 2 extensions	7 518 kg(16,574 lbs)	
Total weight with wide platform + 2 extensions	7 648 kg(16,860 lbs)	
Folded length with standard platform + 1 extension	4,405 m(14 ft 5 in)	Not applicable
Folded length with standard platform + 2 extensions	4,405 m(14 ft 5 in)	
Folded length with wide platform + 2 extensions	4,954 m(16 ft 3 in)	
Unfolded length with standard platform + 1 extension	4,907 m(16 ft 1 in)	Not applicable
Unfolded length with standard platform + 2 extensions	5,887 m(19 ft 4 in)	
Unfolded length with wide platform + 2 extensions	7,508 m(24 ft 8 in)	
Width	2,3 m(7 ft 7 in)	
Maximum side rated slope – On wheels	3°	
Maximum side rated slope – On stabilizers	3°	
Maximum longitudinal rated slope	5°	
Maximum ground pressure of wheel on paved ground – On wheels	14,13 daN/cm ² (205 lb/ft ²)	
Maximum ground pressure of wheel on paved ground – On stabilizers	8,04 daN/cm ² (117 lb/ft ²)	
Maximum load on wheel	4000 daN(8819 lb)	
Outside turning radius – Extension retracted	6,450 m(21 ft 2 in)	
Inside turning radius	3,600 m(9 ft 10 in)	
Maximum working height	15 m(49 ft 3 in)	
Maximum platform height (On stabilizers)	13,4 m(44 ft 0 in)	
Maximum platform height (On wheels)	13 m(42 ft 8 in)	
Overall height of the machine in folded / stowed position (Folding guardrails option)	2,250 m(7 ft 5 in)	
Maximum horizontal reach (With standard platform + 1 extension)	2,202 m(7 ft 3 in)	Not applicable
Maximum horizontal reach (With standard platform + 2 extensions)	3,552 m(11 ft 8 in)	
Maximum horizontal reach (With wide platform + 2 extensions)	4,245 m(13 ft 11 in)	
Maximum outreach above the ground (With standard platform + 1 extension)	1,702 m(5 ft 7 in)	Not applicable
Maximum outreach above the ground (With standard platform + 2 extensions)	3,052 m(10 ft 0 in)	
Maximum outreach above the ground (With wide platform + 2 extensions)	3,745 m(12 ft 3 in)	
Maximum platform capacity	750 kg(1653.47 lb)	
Maximum platform capacity (2 extensions)	750 kg(1,653.47 lbs)	
Capacity when extended	225 kg(496.04 lbs)	
Maximum number of occupants	4	
Maximum person on extension (refer to the capacity on extension recommended)	2	
Maximum wind speed	45 km/h (12,5 m/s) - 28 mph (41 ft/s)	
Manual force	400 N(90 lbf)	
Gradeability	45 %	

B- Familiarization

Machine		HS15 - HS4390			
Drive speed :		<ul style="list-style-type: none"> • 0,5 km/h (0.31 mph) • 1,7 km/h (1.06 mph) • 2,5 km/h (1.55 mph) • 5 km/h (3.11 mph) 			
• Micro-speed					
• Slow speed					
• Medium speed					
• High speed					
Maximum freewheel speed during towed operation		1,7 km/h(1.06 mph)			
Hydraulic tank capacity		76 l20.08 gal US			
Power source - Electric					
Standard	Option	Battery weight	System voltage	Capacity	Capacity
X		440 kg(970 lb)	12V	435 Ah (C20)	435 Ah (C20)

A

B

C

D

E

F

G

H

I

B - Familiarization

CE, UKCA, AS, EAC, CSA and ANSI A92.20 standards

Machine	HS18 - HS5390	
	E	E PRO
Characteristics - Dimensions		
Total weight with standard platform + 1 extension	7 902 kg(17,420 lbs)	Not applicable
Total weight with standard platform + 2 extensions	8 048 kg(17,742 lbs)	
Total weight with wide platform + 2 extensions	8 178 kg(18,029 lbs)	
Folded length with standard platform + 1 extension	4,405 m(14 ft 5 in)	Not applicable
Folded length with standard platform + 2 extensions	4,405 m(14 ft 5 in)	
Folded length with wide platform + 2 extensions	4,940 m(16 ft 2 in)	
Unfolded length with standard platform + 1 extension	4,907 m(16 ft 1 in)	Not applicable
Unfolded length with standard platform + 2 extensions	5,887 m(19 ft 4 in)	
Unfolded length with wide platform + 2 extensions	7,508 m(24 ft 8 in)	
Width	2,3 m(7 ft 7 in)	
Maximum side rated slope — On wheels	2°	
Maximum side rated slope – On stabilizers	1°	
Maximum longitudinal rated slope	5°	
Maximum ground pressure of wheel on paved ground – On wheels	14,86 daN/cm ² (216 lb/ft ²)	
Maximum ground pressure of wheel on paved ground – On stabilizers	8,66 daN/cm ² (126 lb/ft ²)	
Maximum load on wheel	4250 daN(9370 lb)	
Outside turning radius – Extension retracted	6,450 m(21 ft 2 in)	
Inside turning radius	3,600 m(9 ft 10 in)	
Maximum working height	18 m(59 ft 1 in)	
Maximum platform height (On stabilizers)	16,40 m(53 ft 9 in)	
Maximum platform height (On wheels)	11 m(36 ft 10 in)	
Overall height of the machine in folded / stowed position (Folding guardrails option)	2,360 m(7 ft 9 in)	
Maximum horizontal reach (With standard platform + 1 extension)	2,202 m(7 ft 3 in)	Not applicable
Maximum horizontal reach (With standard platform + 2 extensions)	3,552 m(11 ft 8 in)	
Maximum horizontal reach (With wide platform + 2 extensions)	4,245 m(13 ft 11 in)	
Maximum outreach above the ground (With standard platform + 1 extension)	1,702 m(5 ft 7 in)	Not applicable
Maximum outreach above the ground (With standard platform + 2 extensions)	3,052 m(10 ft 0 in)	
Maximum outreach above the ground (With wide platform + 2 extensions)	3,745 m(12 ft 3 in)	
Maximum platform capacity	750 kg(1653.47 lbs)	
Maximum platform capacity (2 extensions)	750 kg(1653.47 lbs)	
Capacity when extended	225 kg(496.04 lbs)	
Maximum number of occupants	4	
Maximum person on extension (refer to the capacity on extension recommended)	2	
Maximum wind speed	45 km/h (12,5 m/s) - 28 mph (41 ft/s)	
Manual force	400 N(90 lbf)	
Gradeability	40 %	
Drive speed :		
• Micro-speed	• 0,5 km/h (0.31 mph)	
• Slow speed	• 1,7 km/h (1.06 mph)	
• Medium speed	• 2,5 km/h (1.55 mph)	
• High speed	• 5 km/h (3.11 mph)	
Maximum freewheel speed during towed operation	1,7 km/h(1.06 mph)	
Hydraulic tank capacity	76 l(20.08 gal US)	

B- Familiarization

Machine		HS18 - HS5390			
Power source - Electric					
Standard	Option	Battery weight	System voltage	Capacity	Capacity
X		440 kg(970 lb)	12V	435 Ah (C20)	435 Ah (C20)

A

B

C

D

E

F

G

H

I

B - Familiarization

4.2 - WORKING AREA / RANGE OF MOTION

HS15E (HS4390E) - HS15E PRO (HS4390E PRO)

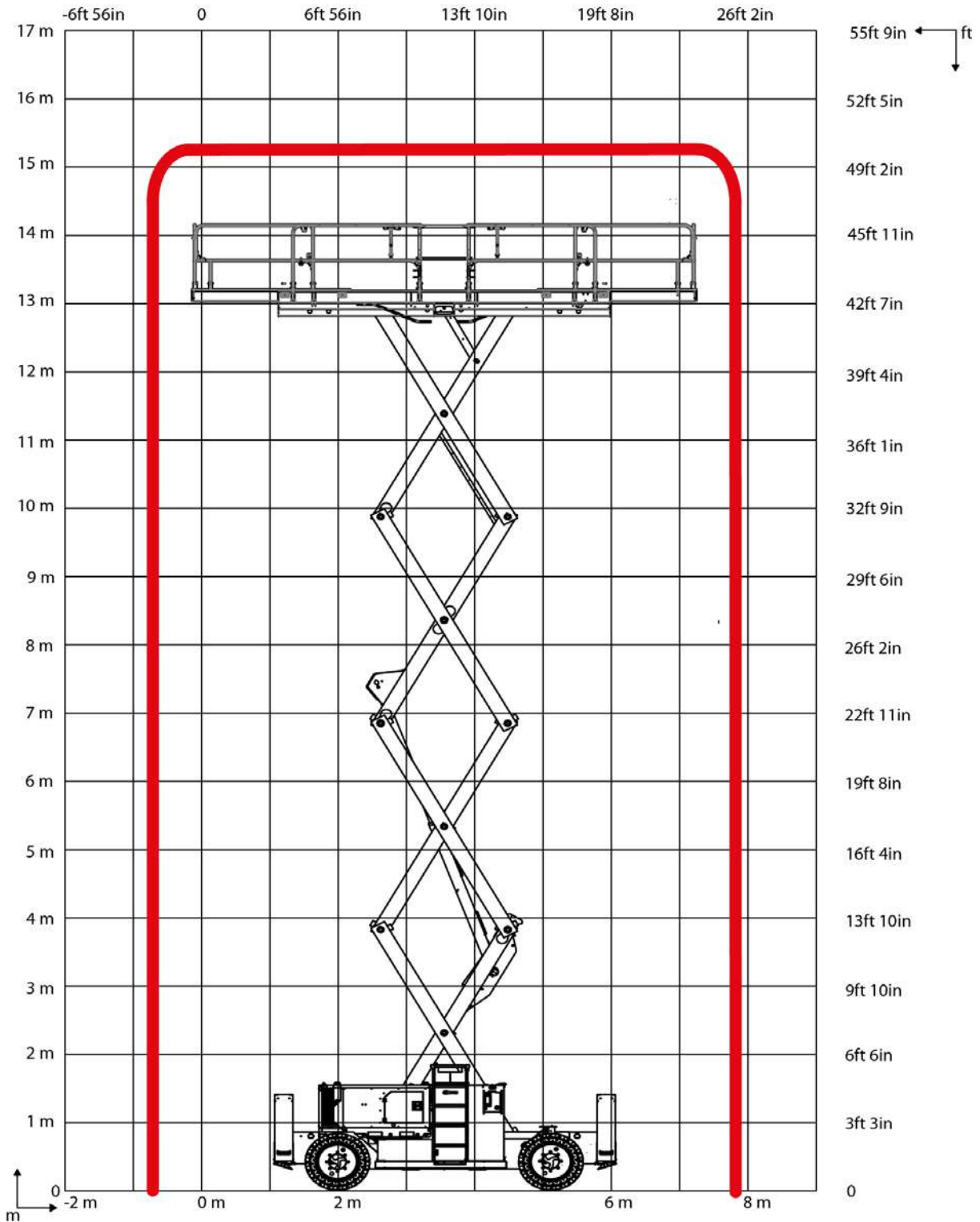

B - Familiarization

HS18E (HS5390E) - HS18E PRO (HS5390E PRO)

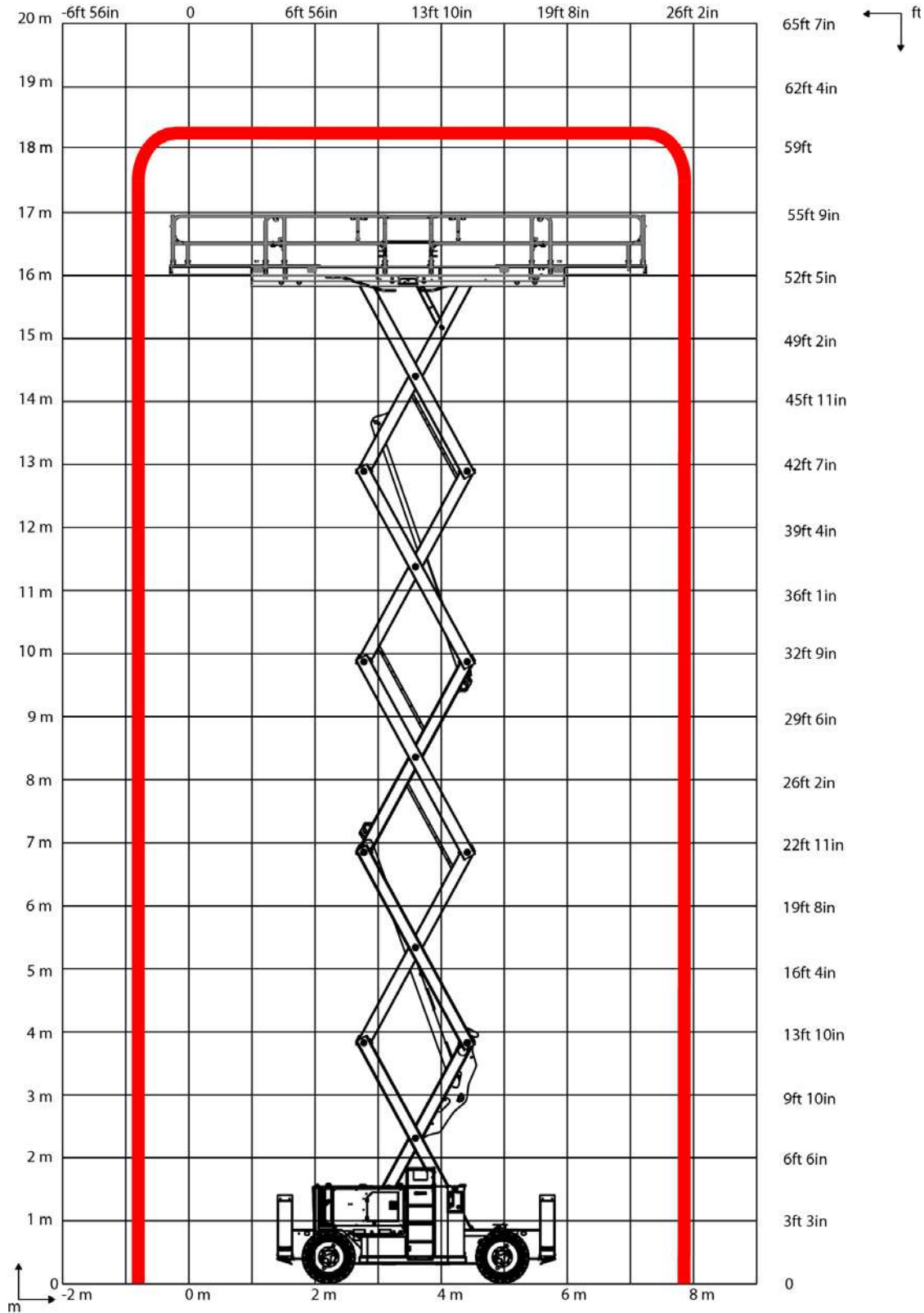

B - Familiarization

5 - Decals and markings locations

CE, UKCA, AS and EAC standards : HS15E - HS15E PRO - HS18E - HS18E PRO

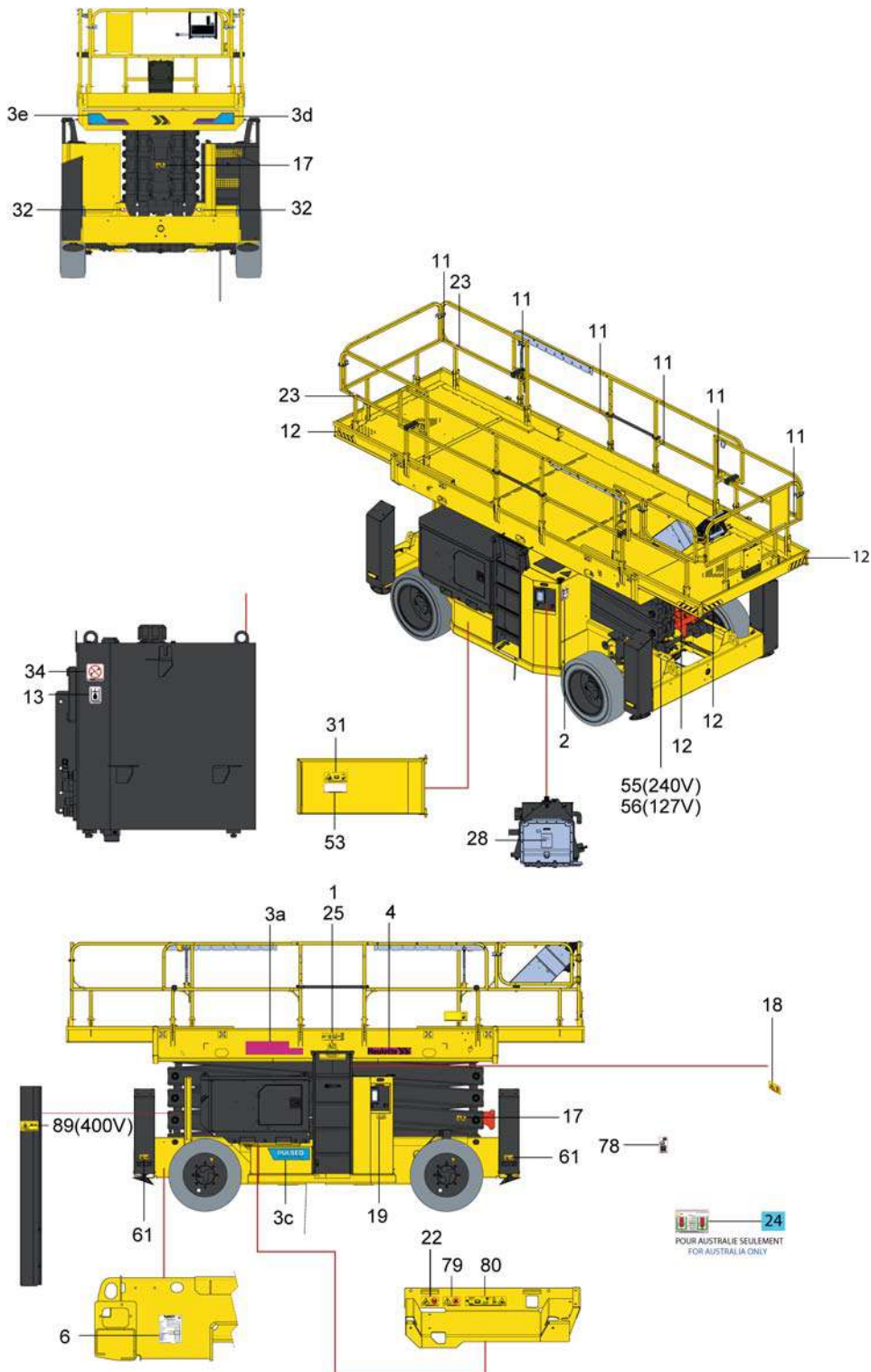

B - Familiarization

CE, UKCA, AS and EAC standards : HS15E - HS15E PRO - HS18E - HS18E PRO

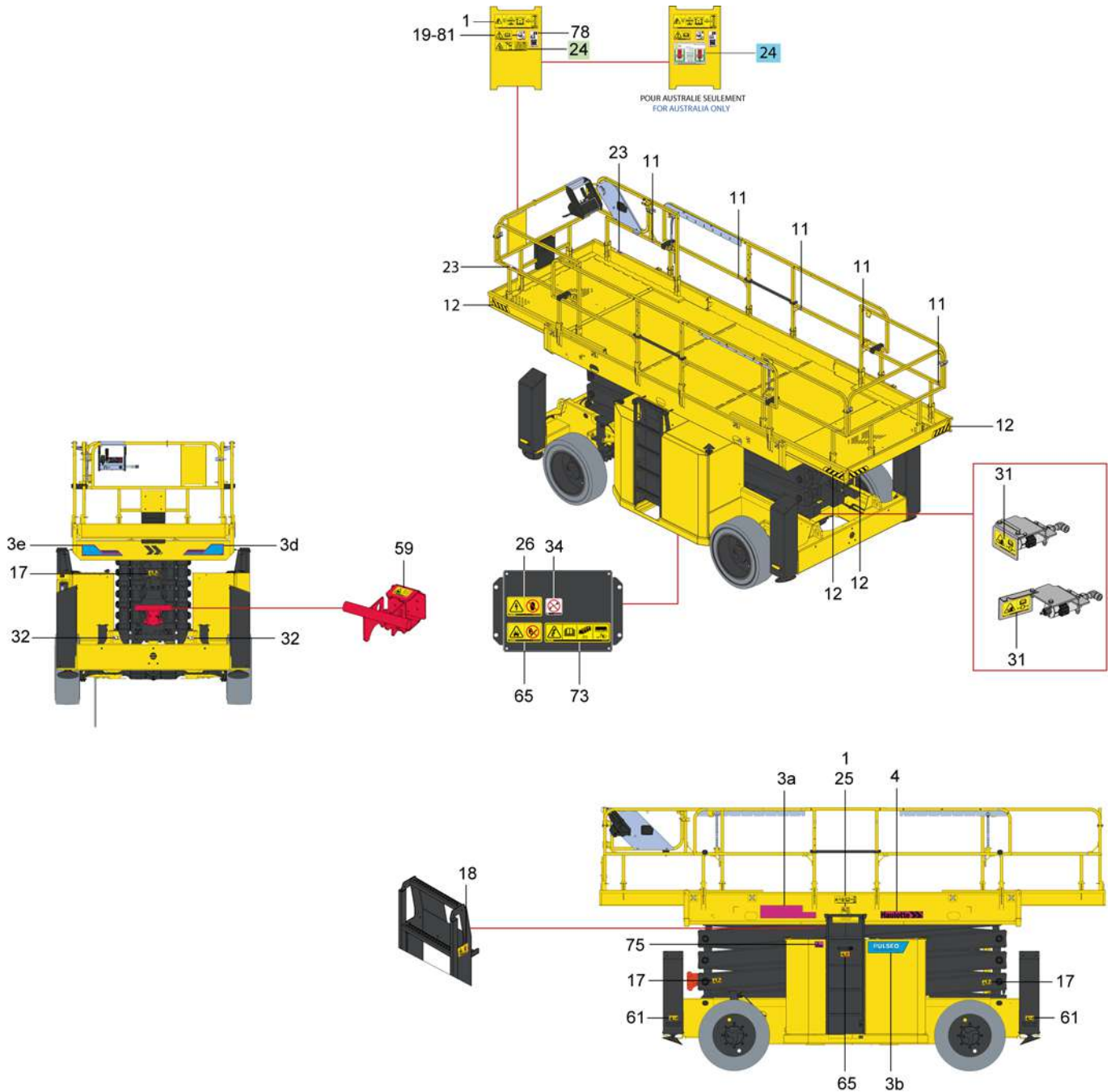

B- Familiarization

CE, UKCA, AS and EAC standards : HS15 E - HS15 E PRO - HS18 E - HS18 E PRO

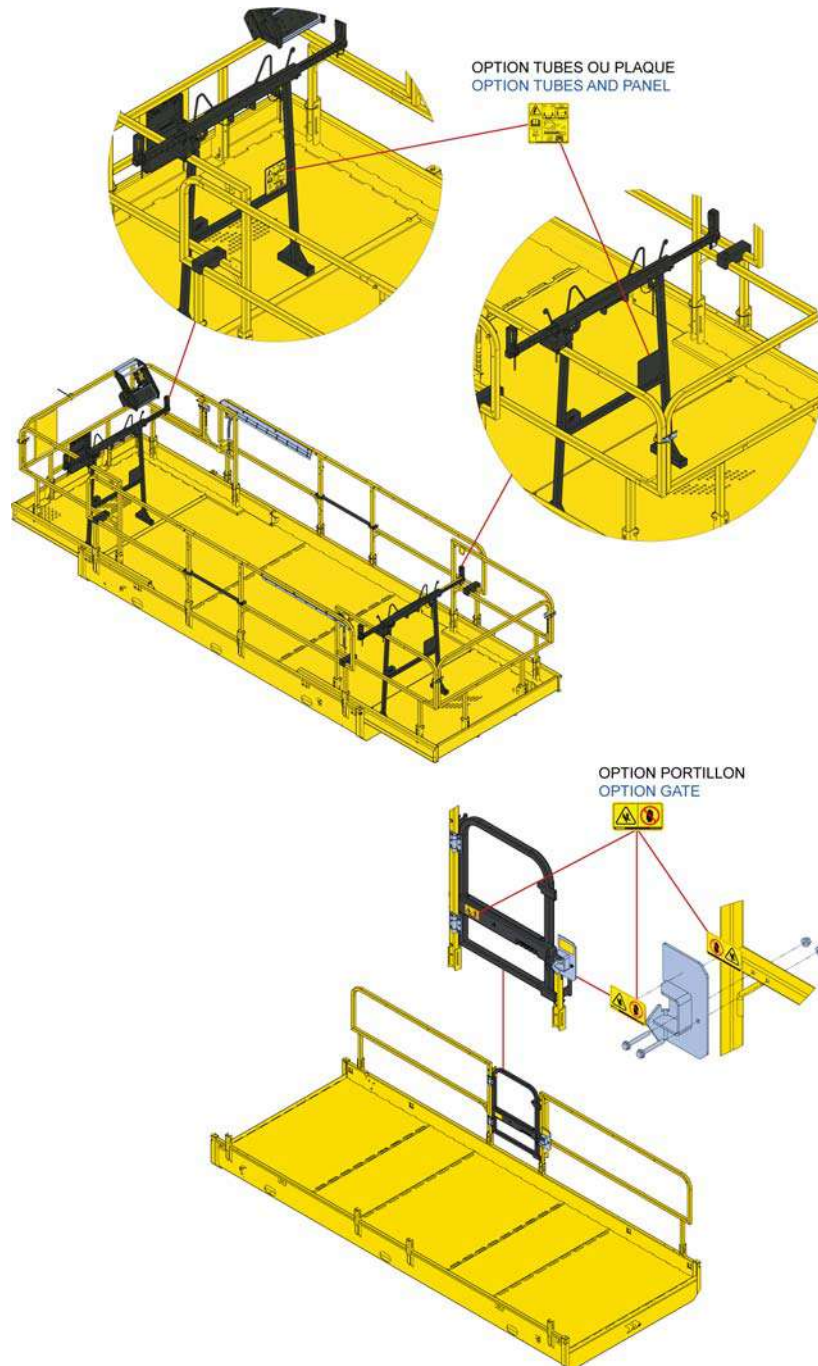

B - Familiarization

CE, UKCA, AS and EAC standards : HS15E - HS15E PRO - HS18E - HS18E PRO

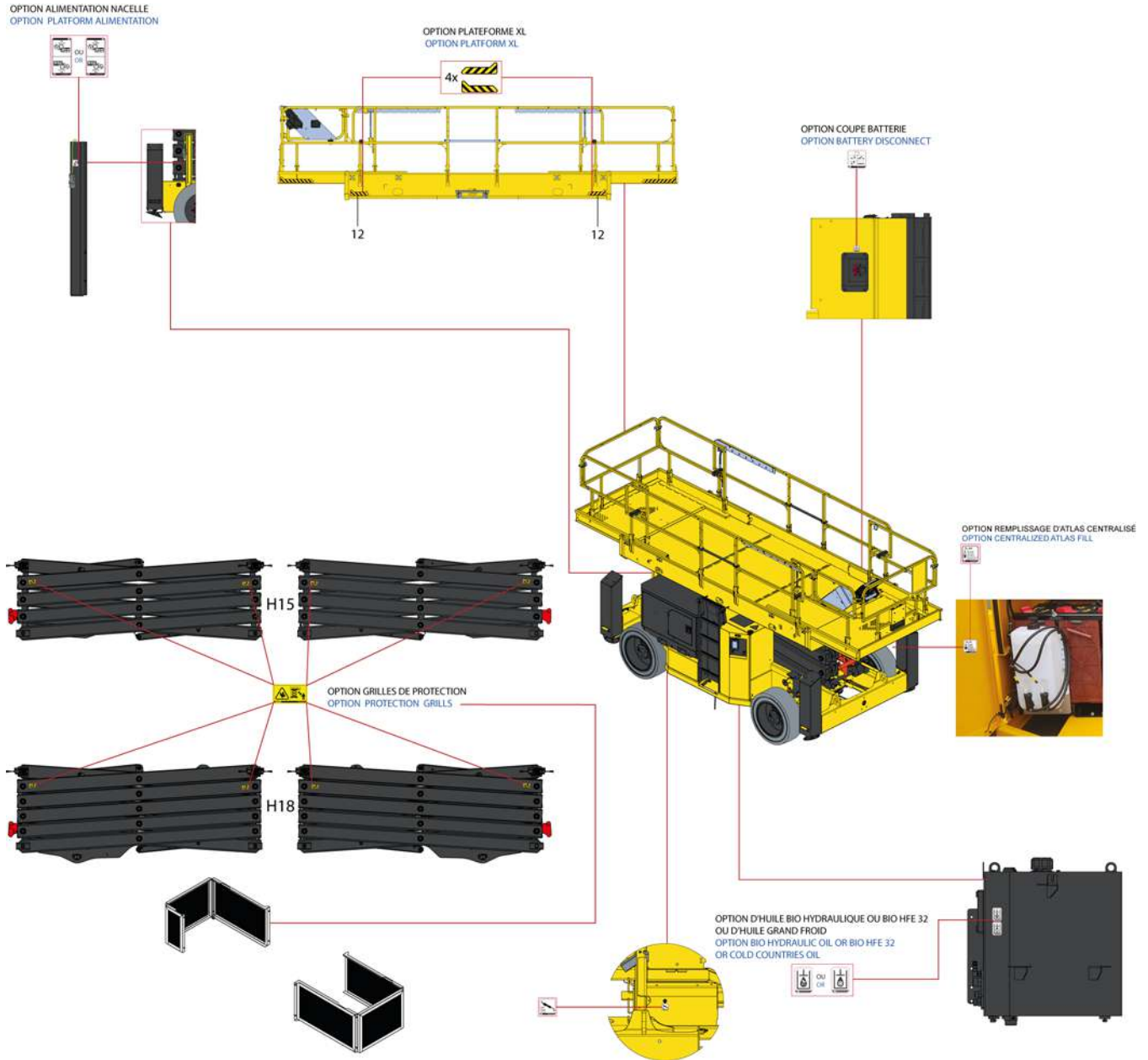

B - Familiarization

CE, UKCA, AS and EAC standards : HS15E - HS15E PRO - HS18E - HS18E PRO

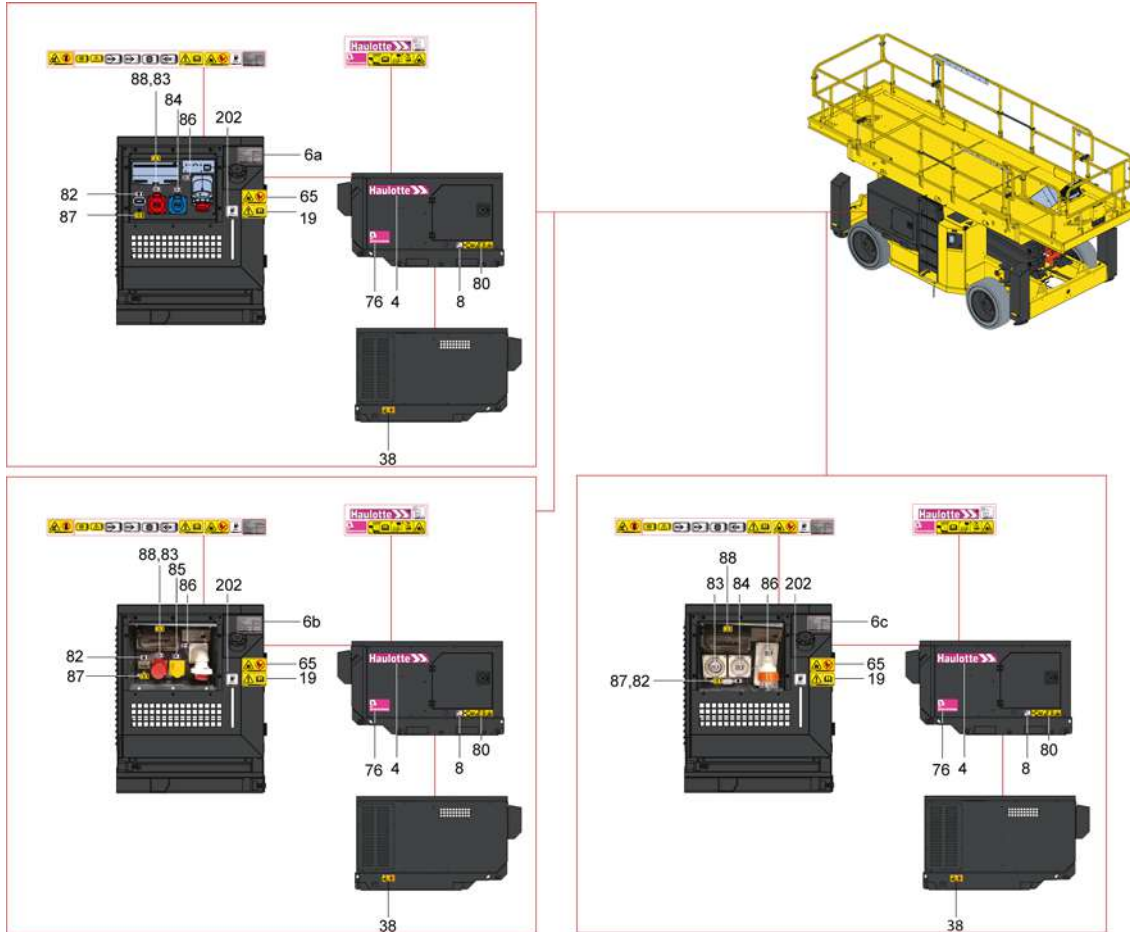

B- Familiarization

CE, UKCA, AS and EAC standards : HS15 E -
HS15 E PRO - HS18 E - HS18 E PRO

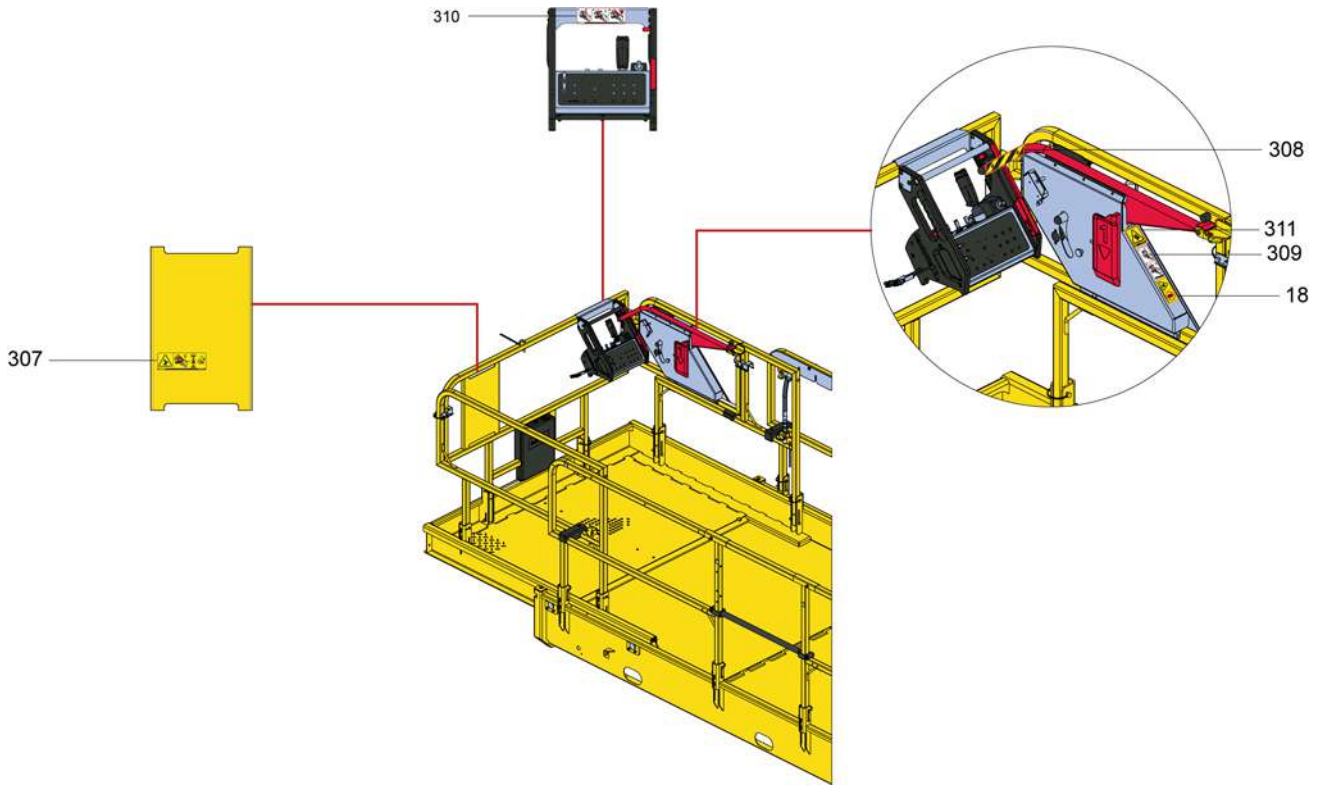

B - Familiarization

CE, UKCA, AS and EAC standards : HS15 E - HS15 E PRO - HS18 E - HS18 E PRO

Marking	Description	Quantity	HS15 E - HS15 E PRO	HS18 E - HS18 E PRO
1	Height of the floor and load	3	4001068780	4001068790
2	Pressure - Stress on the floor + Maximum effort on the stabilizers + Transport height	1	4001129000	4001129730
3a	Commercial name - HS15E / HS4390E LIGHT	2	4001072080	N/A
3a	Commercial name - HS15E / HS4390E DARK	2	4001129850	N/A
3a	Commercial name - HS15E PRO / HS4390E PRO LIGHT	2	4001072090	N/A
3a	Commercial name - HS15E PRO / HS4390E PRO DARK	2	4001129860	N/A
3a	Commercial name - HS18E / HS5390E LIGHT	2	N/A	4001072100
3a	Commercial name - HS18E / HS5390E DARK	2	N/A	4001129870
3a	Commercial name - HS18E PRO / HS5390E PRO LIGHT	2	N/A	4001072110
3a	Commercial name - HS18E PRO / HS5390E PRO DARK	2	N/A	4001129880
3b	Decal PULSEO GENERATION - Left	1	40010722270	
3c	Decal PULSEO GENERATION - Right	1	40010722280	
3d	Decal PULSEO GENERATION - Left platform	2	40010722290	
3e	Decal PULSEO GENERATION - Right platform	2	4001072300	
4	Decal HAULOTTE® - 495 X 80 - Bright machine	2	4001072210	
4	Decal HAULOTTE® - 495 X 80 - Dark machine	2	4001072220	
6a	Identification plate	1	For CE and AS standards only : 4000700160	
6b	Identification plate	1	For Russia : 4000278870	
6c	Identification plate	1	For Ukraine : 307P227830	
6d	Identification plate	1	UKCA standard only : 4001188820	
11	Lanyard attachment points	11	4001052020	
12	Yellow and black adhesive tape	8	4001052030	
13	Hydraulic oil	1	4001052050	
17	Risk of crushing	5	4001052070	
18	Hand crushing hazard - Risk of crushed hands	2	4001052080	
19	Read the operation manual	2	4001052090	
22	Wound foot	1	4001073700	
23	Driving direction	2	4001052110	
24	Danger of electrocution	1	For CE and EAC standards only 4001052120	
24	Danger of electrocution	2	AS standard only : 4001052140	
25	Closing drop rail	2	4001052150	
26	Ground for welding	1	4001052160	
28	Software version	1	4000504670	
31	Brake release	3	4001073710	
32	Anchorage point - Traction	4	4001052180	
34	Do not high-pressure wash	2	4001052200	
53	Emergency lowering	1	4001073540	
55	240 V charger socket	1	4001110960	
56	127 V charger socket	1	4001110970	
59	Scissors safety	1	4001052240	
61	Risk of crushed feet	4	4001052260	
65	Danger of fire	1	4001052270	
73	Battery mass	1	4001074280	
75	Battery management – Bright machine	1	4001053460	
75	Battery management – Bright machine	1	4001053510	
78	QR Code ( https://www.e-technical-information.com)	2	4001089310	
80	Assembly procedure – Range Extender	1	4001074890	
81	Control unit position	1	4001074900	
87	400V 16A charger socket	1	4001134700	
89	Do not store	1	4001074880	

B - Familiarization

Marking	Description	Quantity	HS15 E - HS15 E PRO	HS18 E - HS18 E PRO	
4	Range Extender	1	4001072220		
6		1	4001128580 / 4001128590 / 4001128600		
8		1	4001068990		
19		1	4001052090		
38		1	4001075820		
76		1	4001072970		
80		1	4001074890		
83		1	4001075850 / 4001075860		
84		1	4001075870		
85		1	4001075880		
86		1	4001128990		
91		1	4001075830		
92		1	4001075840		
202		1	4001076200		
18		Option Activ'Shield Bar Scissors	1	4001052080	
307			1	4001085530	
308	1		4001085540		
309	1		4001085550		
310	1		4001085560		
311	1		4001098550		
Not illustrated	Biodegradable hydraulic oil option	1	4001052380		
Not illustrated	Biodegradable hydraulic oil option – Cold country	1	4001052390		
Not illustrated	Compressed air option	1	4001052370		
Not illustrated	Centralized filling option	1	4001052340		
Not illustrated	Pipe holder option	1	4001134730		
Not illustrated	Plate holder option	1	4001134730		
Not illustrated	Battery disconnection option	1	4001073740		
Not illustrated	Platform extension option	1	4001052030		
Not illustrated	Option Grill	6	4001052080		
Not illustrated	XL platform option	1	4001052030		
Not illustrated	Power plug option	1	4001052350 / 4001052360		
Not illustrated	Option - Working area / Range of motion (1 extension)	1	4001194580	4001194590	
Not illustrated	Option - Working area / Range of motion (2 extensions)	1	4001158530	4001158550	
Not illustrated	Option - Working area / Range of motion (Large platform)	1	4001158540	4001158560	

B - Familiarization

ANSI and CSA standards : HS4390E - HS4390E PRO - HS5390E - HS5390E PRO

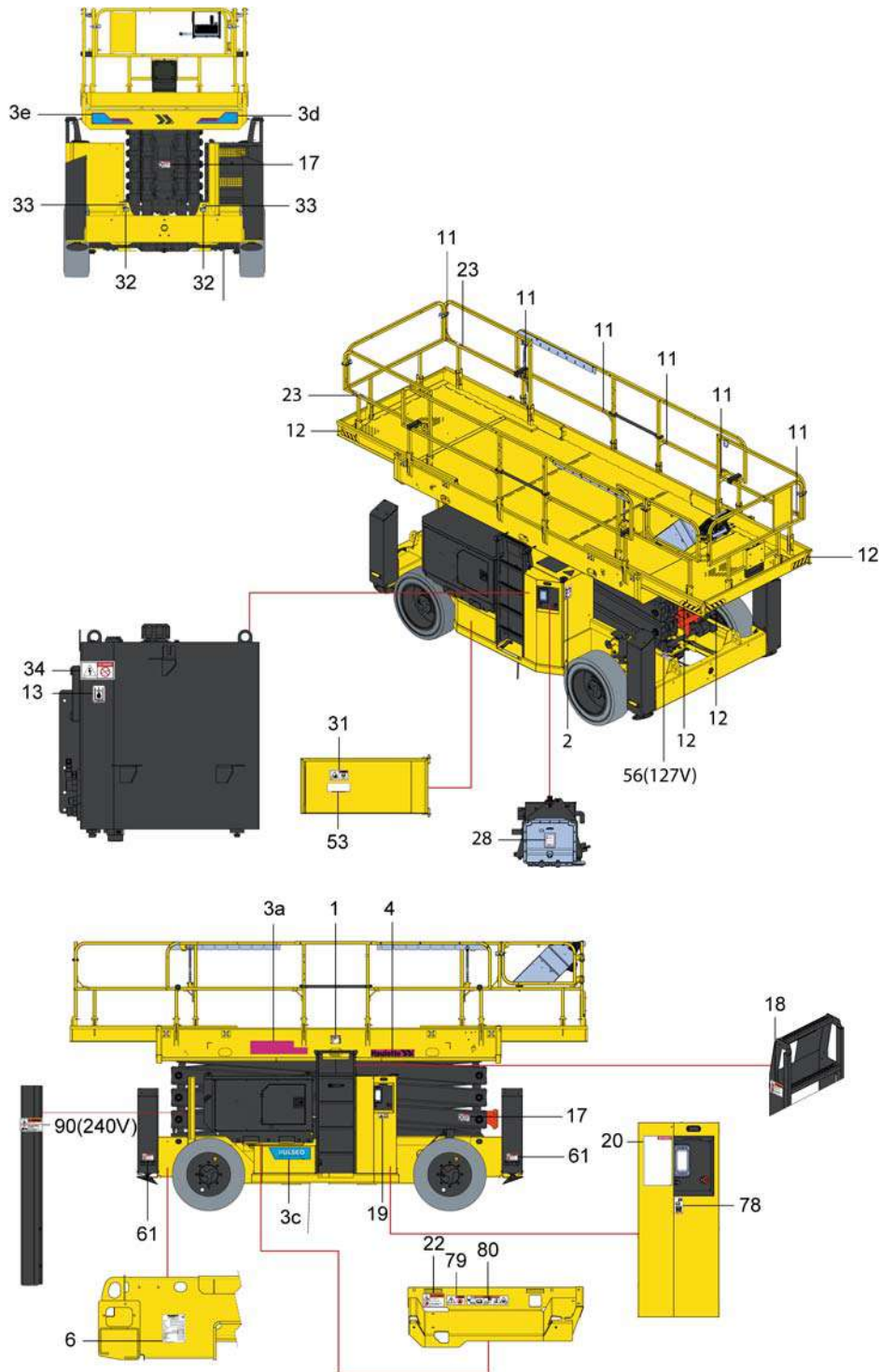

B- Familiarization

ANSI and CSA standards : HS4390E - HS4390E PRO - HS5390E - HS5390E PRO

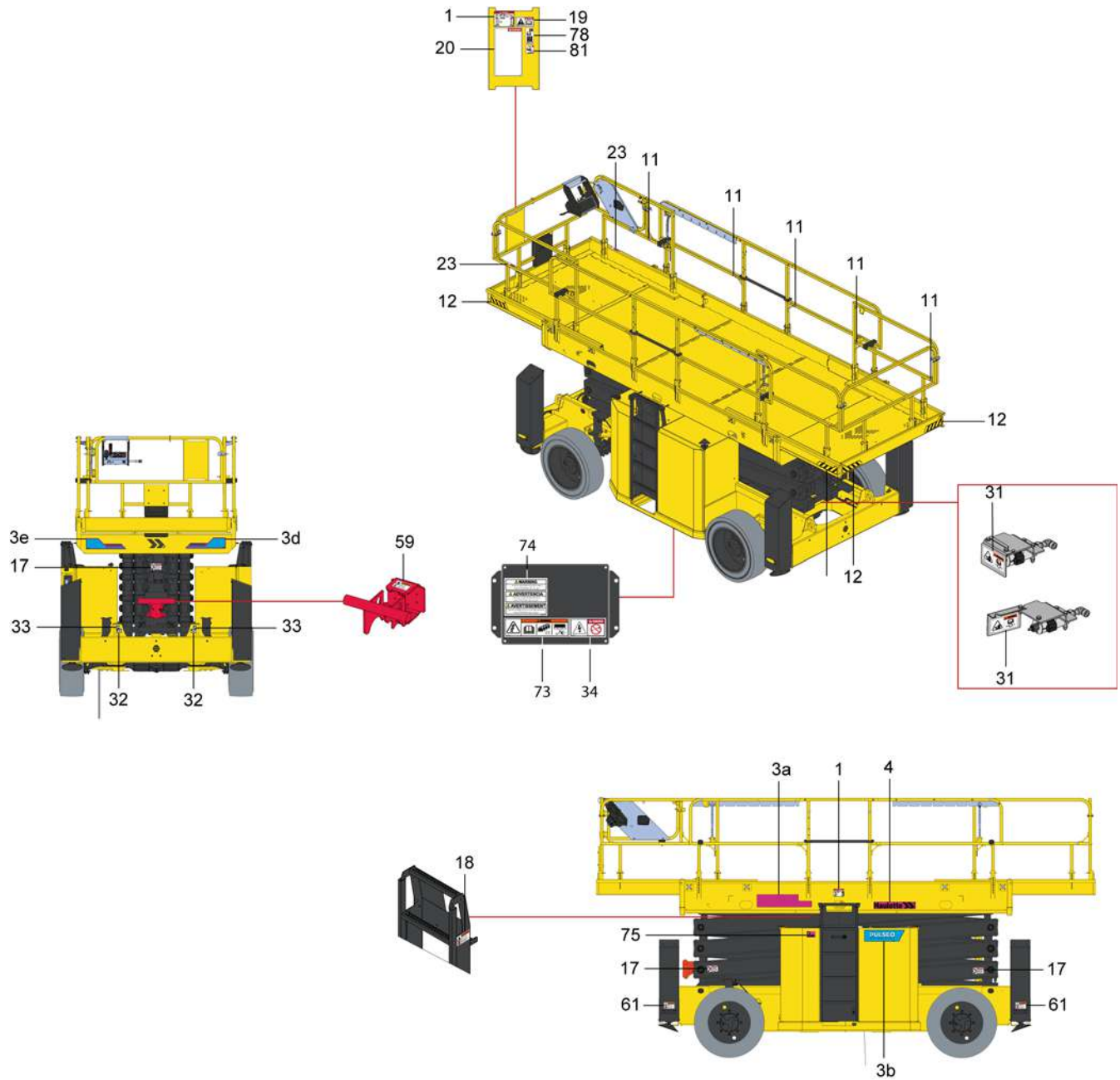

B - Familiarization

ANSI and CSA standards : HS4390E - HS4390E PRO - HS5390E - HS5390E PRO

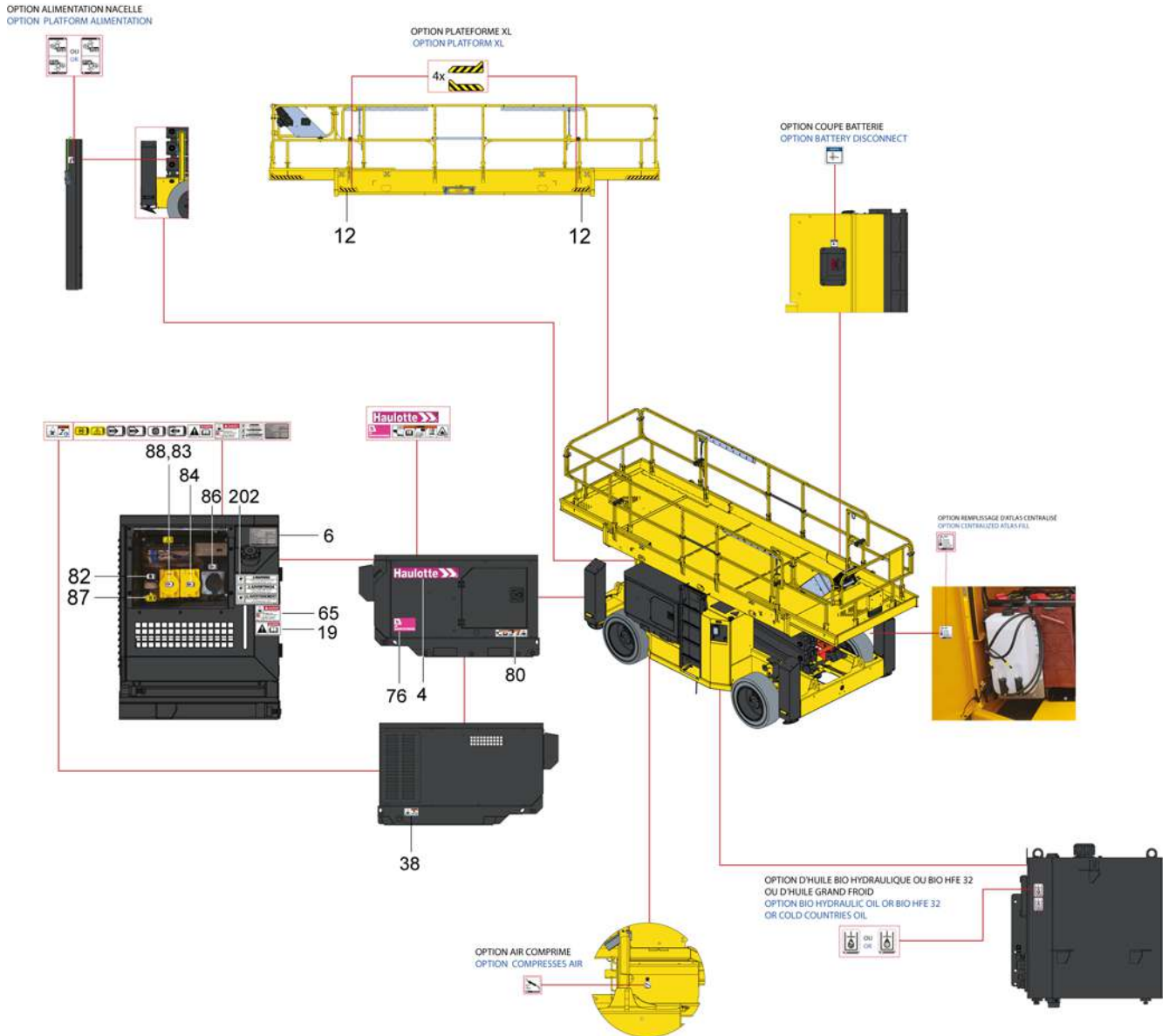

A

B

C

D

E

F

G

H

I

B- Familiarization

ANSI and CSA standards : HS4390E - HS4390E PRO - HS5390E - HS5390E PRO

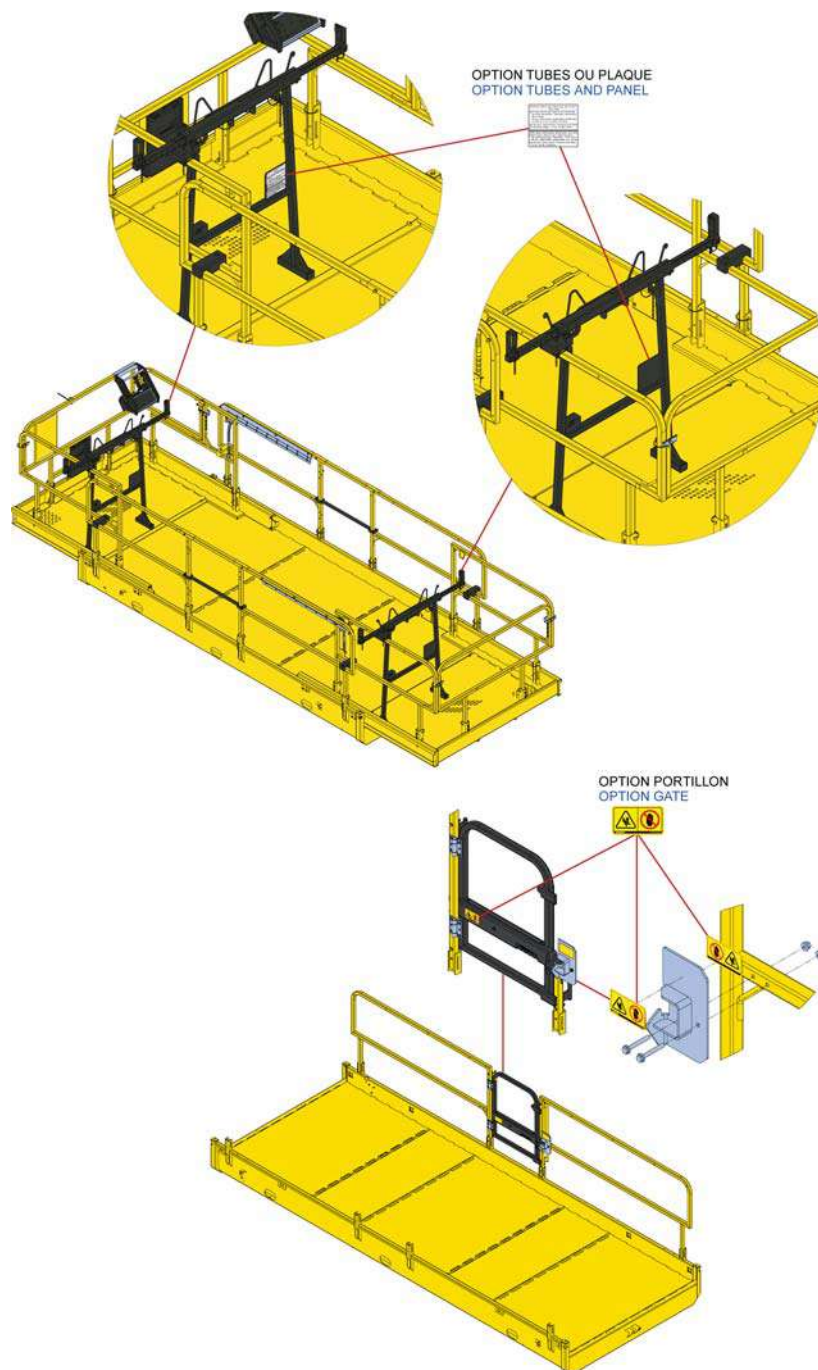

B - Familiarization

ANSI and CSA standards : HS4390E - HS4390E PRO - HS5390E - HS5390E PRO

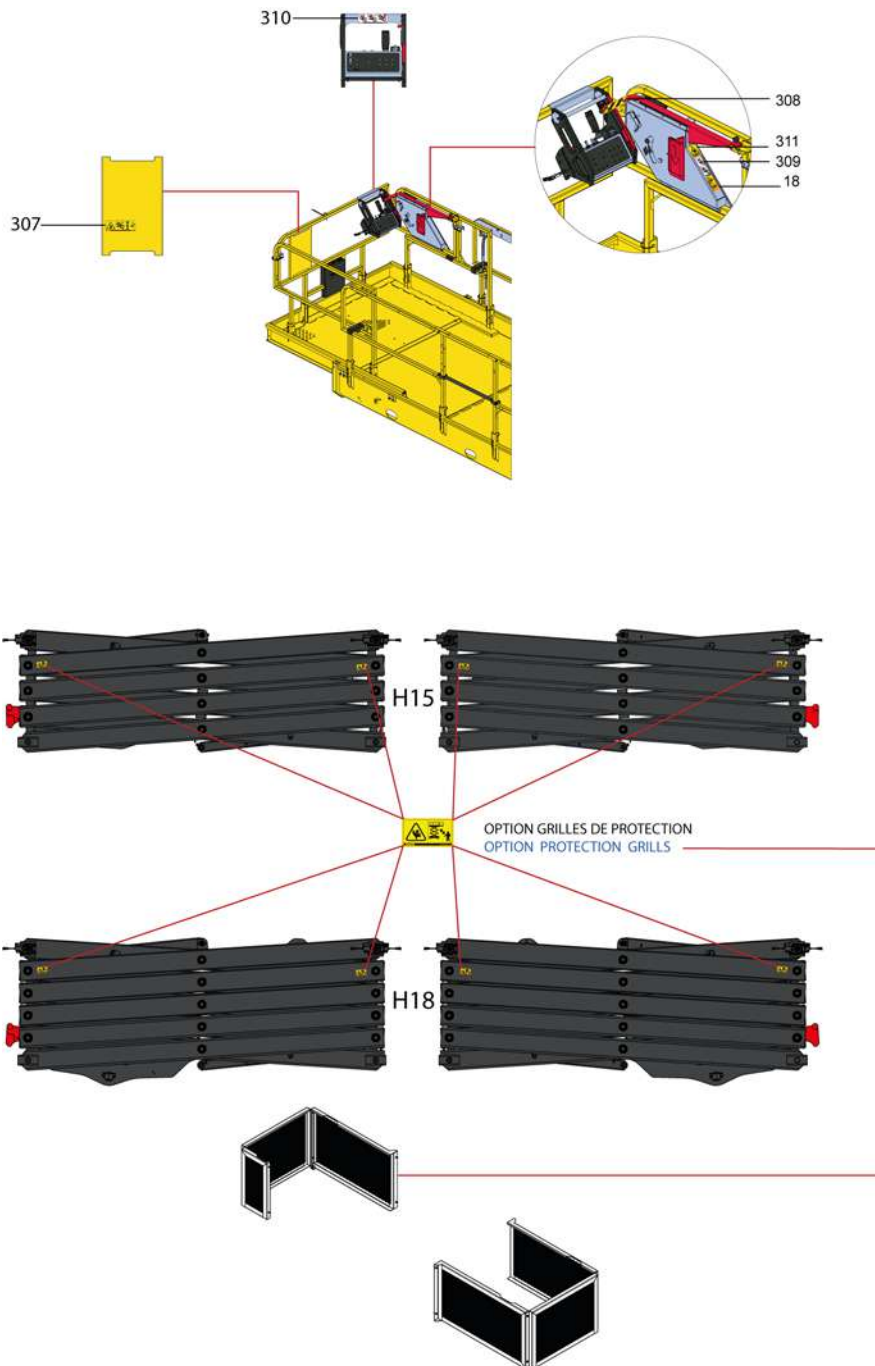

B- Familiarization

ANSI and CSA standards : HS4390 E - HS4390 E PRO - HS5390 E - HS5390 E PRO

Marking	Description	Quantity	HS4390 E - HS4390 E PRO	HS5390 E - HS5390 E PRO
1	Height of the floor and load	3	4001132870	4001132880
2	Pressure – Stress on the floor + Maximum effort on the stabilizers + Transport height	1	4001129000	4001129730
3a	Commercial name - HS15E / HS4390E LIGHT	2	4001072120	N/A
3a	Commercial name - HS15E / HS4390E DARK	2	4001129890	N/A
3a	Commercial name - HS15E PRO / HS4390E PRO LIGHT	2	4001072130	N/A
3a	Commercial name - HS15E PRO / HS4390E PRO DARK	2	4001129900	N/A
3a	Commercial name - HS18E / HS5390E LIGHT	2	N/A	4001072140
3a	Commercial name - HS18E / HS5390E DARK	2	N/A	4001129910
3a	Commercial name - HS18E PRO / HS5390E PRO LIGHT	2	N/A	4001072150
3a	Commercial name - HS18E PRO / HS5390E PRO DARK	2	N/A	4001129920
3b	Decal PULSEO GENERATION - Left	1		40010722270
3c	Decal PULSEO GENERATION - Right	1		40010722280
3d	Decal PULSEO GENERATION - Left platform	2		40010722290
3e	Decal PULSEO GENERATION - Right platform	2		4001072300
4	Decal HAULOTTE® - 495 X 80 - Bright machine	2		4001072210
4	Decal HAULOTTE® - 495 X 80 - Dark machine	2		4001072220
6	Identification plate	1		4000700170
11	Lanyard attachment points	11		4001052020
12	Yellow and black adhesive tape	8		4001052030
13	Hydraulic oil	1		4001052050
17	Risk of crushing	5		4000024640
18	Hand crushing hazard - Risk of crushed hands	2		In english : 4000024770 In french : 4000067710 In spanish : 4000086490
19	Read the operation manual	2		4000025140
20	Before operation – Vertical	2		4000027570
22	Wound foot	1		4000024840
23	Driving direction	2		4001052110
28	Software version	1		4000504670
31	Brake release	1		4001133750
32	Anchorage point - Traction	4		4000027310
33	Anchorage point - Elevation	4		4000027330
34	Do not high-pressure wash	2		4000025130
53	Emergency lowering	1		4001073540
56	127 V charger socket	1		400113690
59	Scissors safety	1		In english : 4000024850 In french : 4000068070 In spanish : 4000086500
61	Risk of crushed feet	4		In english : 4000024780 In french : 4000067700 In spanish : 4000086480
73	Battery mass	1		4001134160
74	California warning - P65			4001026850
75	Battery management – Bright machine	1		4001053460
75	Battery management – Bright machine	1		4001053510
78	QR Code ( https://www.e-technical-information.com)	2		4001089310
80	Assembly procedure – Range Extender	1		4001128970
81	Control unit position	1		4001074900
88	240V 25A charger socket	1		4001134700
89	Do not store	1		4001134640

B - Familiarization

Marking	Description	Quantity	HS4390 E - HS4390	HS5390 E - HS5390	
			E PRO	E PRO	
4	Range Extender	1		4001072220	
6		1		4001128610	
19		1		4000025140	
38		1		4000027450	
76		1		4001072970	
80		1		4001128970	
83		1		4001129050	
84		1		4001129060	
85		1		4001075880	
86		1		4001128990	
91		1		4001075830	
92		1		4001129040	
202		1		4001126880	
18		Option Activ'Shield Bar Scissors	1		4001052080
307			1		4001085530
308	1			4001085540	
309	1			4001085550	
310	1			4001085560	
311	1			4001098550	
Not illustrated	Biodegradable hydraulic oil option	1		4001052380	
Not illustrated	Biodegradable hydraulic oil option – Cold country	1		4001052390	
Not illustrated	Compressed air option	1		4001052370	
Not illustrated	Pipe holder option	2		4000131650	
Not illustrated	Plate holder option	2		4000131730	
Not illustrated	Battery disconnection option	1		4001167960	
Not illustrated	Centralized filling option	1		4001052340	
Not illustrated	Platform extension option	1		4001052030	
Not illustrated	Option Grill	6		4001052080	
Not illustrated	XL platform option	1		4001052030	
Not illustrated	Power plug option	1		4001052350	

C - Pre-operation inspection

1 - Recommendations

The owner, the site manager, the supervisor and the operator are all responsible to ensure the machine is fit for the work it is to perform; i.e. that the machine is suitable to carry out the work in complete safety and in compliance with this Operator's Manual. All managers who are responsible for persons operating the machine must be familiar with the local regulations currently applicable in the country of use and ensure that they are adhered to.

Before using the machine, read the previous chapters in this manual. Ensure that you have understood the following points :

- Safety precautions.
- Operator's responsibilities.
- Conditions and the operating principles of the machine.

2 - Working area assessment

Before any operation :

- Carry out a thorough inspection of the site to identify any potential risks within the work zone.
- Take the necessary precautions to avoid collisions with other machinery within the work zone.

Ensure that :

- The weather conditions (wind, rain, etc.) allowing the machine to be used.
- The ground withstands the weight of the machine and has not been affected by the poor weather conditions.
- Check that the authorisations to work with the machine on the site in question have been obtained (.g. chemical product factories).
- Define a rescue plan for all the risks, including the risk of falls and crushing.

A

B

➤ C

D

E

F

G

H

I

C - Pre-operation inspection

3 - Inspection and Functional test

3.1 - DAILY INSPECTION

Each day before the beginning of a new work session and with each change of operator, the machine must be subjected to a visual inspection and a complete functional test.



- Never use a defective or a malfunctioning aerial work platform.
- If any item on the check list is marked "No" during the inspection; machine must be tagged and placed out of service.
- Do not operate the machine until all identified items are corrected and it has been declared safe for operation.

In case of loose fasteners, refer to torque table value in maintenance book.

In case of leaks, replace the damaged part before use.

In case of structural part deformation (cracks, broken weld, paint chips) replace the part before use.



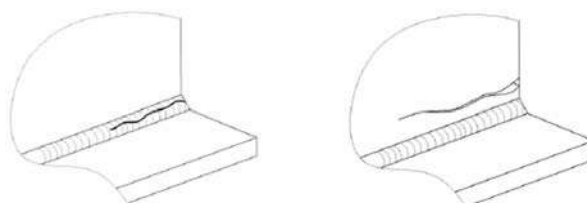





S a m p l e o f b r o k e n w e l d s



We recommend these forms to be completed daily and stored to assist with your maintenance schedule.

Each action is depicted in the daily inspection sheet using the following symbols.

Use the detailed program below.

	Oil change		Lubrication-Lubrication		Tightening
	Levelling		Systematic replacement		Functional adjustments / Checks / Cleaning
	Visual inspection		To check by test		

Serial number :	
Hours of operation :	
HAULOTTE Services® contract reference :	
Intervention record number :	
Date :	
Name :	
Model :	
Signature :	

C - Pre-operation inspection

A

B

C

D

E



















F

G

H



















I

HS15 E (HS4390 E) - HS15 E PRO (HS4390 E PRO) - HS18 E (HS5390 E) - HS18 E PRO (HS5390 E PRO)

	Page or associated procedure	Daily	OK	NOK	Corrected	Comments
Chassis assembly : Wheel, reducer, steering, wheel pivot						
Check state of tires/tyres and inflations						
Clean the pads slide						
Check the pads : Tightening , Attendance						
Check leakage(s)on the oscillation cylinders						
Inspect the brake release solenoid valve cover						
Range extender (if equipped)						
Check engine fuel level (Top up the oil if necessary)						
Check engine oil level (Top up the oil if necessary)						
No leaks from engine components (engine, hoses, radiator)						
Check the condition of the battery						
Batteries						
Check the condition of the battery						
Hydraulic : oils, filters and hoses						
Check the hydraulic oil level (Top up the oil if necessary ; Machine stowed)						
Check the clogging indicator on the hydraulic pressure filter (change if clogged)						
Check the hoses, blocks and pumps, fittings, cylinders and the tank for the absence of leaks, deformations and damage						
Platform						
Ensure that the gate or sliding bar shall be designed to either return automatically to the closed and latched position						
Check that the harness anchor points are not cracked or damaged						
Clean the platform extension						
Check the quick ties and the good location of the guardrail						

C - Pre-operation inspection

HS15 E (HS4390 E) - HS15 E PRO (HS4390 E PRO) - HS18 E (HS5390 E) - HS18 E PRO (HS5390 E PRO)

	Page or associated procedure	Daily	OK	NOK	Corrected	Comments
General						
Check for the presence, cleanliness and readability of the manufacturer's plates, security labels, user manual and maintenance manual						
Check the cleanliness and readability of the control box						
Test the opening and closure of covers (chassis, turntable, upper control box)						
Check the condition of electrical harnesses, cables and connectors						
Check for the absence of abnormal noise and jerky movements						
Check for the absence of visible deterioration and damage						
Check for the absence of cracks, broken welds and chipped paintwork on the structure						
Check for the absence of missing or loose screws and bolts						
Check for the absence of deformation, cracking and breakage of axis stops, bushing and axes						
Check for the absence of foreign bodies in joints and sliding parts						
Safety devices						
Test the operation of the upper and lower control boxes: manipulators, switches, buttons, horn, emergency stops, screens and lights						
Check the absence of visual and audible alarms						
Test the operation of the tilt system						
Test the operation of the emergency lowering system						
Test the operation of the axle locking system						
Test the operation of the loading control system (visual alarm on the control box)						
Test the operation of the Activ Shield Bar (If equipped)						

C - Pre-operation inspection

4 - Safety functional checks

To protect the user and the machine, safety systems prevent the movement of the machine beyond its operating limits. These safety systems when activated immobilize the machine and prevent further movement.

The operator must be familiar with this technology and understand that is not a malfunction but an indication that the machine has reached an operation limit.

Aerial Work platforms are equipped with two control boxes which allow operators to safely use the machine. An auxiliary system (Overriding system) is available on the ground control box in order to rescue anyone trapped on the platform.

The following checks describe the operation of the machine and the specific controls required.

For the location and description of these controls :  refer to section B 3.2 and D 2 - Ground control box and B 3.3 and D 3 - Platform control box.

4.1 - E-STOP BUTTON CHECK

Machine switched on :

Ground control box E-stop button

Step	Action
1	Pull the E-Stop button (9) at the ground control box.
2	Set the key switch (21) at ground box to the  position.
3	The indicator (10) lights up on ground control box.
4	Push the E-stop button (9).
5	Check that the on-board screen turns off
6	Check no movements are functional.

Platform control box E-stop button

Step	Action
1	Pull both E-Stop buttons (9) at ground box and (1) at platform box.
2	Set the key switch (21) at ground box to the  position.
3	The indicator (13) lights up on ground control box.
4	Push in E-Stop button (1) at platform.
5	Check no movements are functional. The indicators go out.

A

B

C

D

E

F

G

H

I

C - Pre-operation inspection

4.2 - ACTIVATION OF CONTROLS

The enable switch must be active to allow any movement.

The "Enable Switch" system depends on the machine configuration and will consist of one of the following :

- Enable trigger on platform control joystick : Press the trigger and perform a movement. Release the trigger. The movement stops
- Foot pedal (enable switch) in the platform (Optional) : Press on the pedal and perform a movement. Release the pedal. The movement stops.
- Enable switch at ground box : Press and hold the Enable Switch for more than 6 s and simultaneously press on the platform raise / lower control (5). No movement is performed.
- Enable switch on platform control station

4.3 - FAULT DETECTOR

The machine is equipped with an on-board fault detection system, which indicates the type of fault to the operator.

The fault is identified by a default code.

The default code is displayed at the ground control box.

According to the type of fault, the machine MAY switch into DOWNGRADEMODE mode and certain movements are prevented to maintain Operator's safety.

Do not use the machine until the fault has been corrected.

4.3.1 - Indicators/LED's test

From the ground control box

Step	Action
1	Pull the E-Stop button (9) at the ground control box.
2	Set the key switch (21) at ground box to the  position
3	Check that the LEDs (10, 13, 15, 16) light up on ignition and that the display is also lit up
4	Check that the LED's (13, 15, 16) on the display are all turned off after 1 sec.

From the platform control box

Step	Action
1	Pull the E-Stop button (9) at the ground control box.
2	Set the key switch (21) at ground box to the  position
3	Check that the LEDs (13, 15, 16) light up on ignition and that the display is also lit up
4	First push in the E-Stop button (1) at platform box, then pull out.
5	Verify that all the (2, 3, 5, 6, 8, 9, 10, 11, 12, 13, 14, 17, 18, 19, 2, 21, 22, 24, 25, 26, 27) LEDs are lit on the platform control station.
6	Verify that the (2, 3, 5, 6, 8, 9, 10, 11, 12, 13, 14, 17, 18, 19, 2, 21, 22, 24, 25, 26, 27) LEDs on the display panel turn off after 1 seconds.



C - Pre-operation inspection

4.3.2 - Buzzers test

From the ground control box

Step	Action
1	Pull the E-Stop button (9) at the ground control box.
2	Set the key switch (21) at ground box to the  position.
3	Verify that the buzzers at the ground and platform beep.

4.4 - AUTOMATIC ENGINE CUT-OUT (IF MACHINE EQUIPPED WITH THE OPTION RANGE EXTENDER)

If the machine is in Forced Mode   , the engine automatically cuts out in the following conditions :

- The alternator is not functioning.
- Engine temperature is too high.
- Oil pressure is too low.
- The E-stop(s) is (are) pushed in.
- The machine is switched off.

4.5 - OVERLOAD SENSING SYSTEM

If the platform load exceeds the maximum allowed load, no movement is possible from the 2 control boxes.

At ground and platform control boxes a buzzer sounds and an indicator light warns the operator.

To return the machine to normal operation remove weight from the platform until the load is below the maximum allowed load.

Daily check that the LED's illuminate when the machine is switched on :

- Verify that the Overload system is active : Refer to Indicator (15) at ground control box and LED (13) at platform control box display.
- Verify that the buzzers are functioning : Refer to Buzzers test.

A periodic inspection of this device must be performed according to the recommendation in Maintenance Schedule.

C - Pre-operation inspection

4.6 - OSCILLATING AXLES (IF EQUIPPED)

To improve the driving capability on rough terrain, the front axle is equipped with an oscillating mechanism. When the scissor arms are folded, the oscillating axle is unlocked to adapt to uneven ground and help machine stability. When the scissor arms are extended, a safety device locks the oscillating axle to reduce overturning hazard.

A visual inspection must be performed to ensure the absence of leaks from the oscillating cylinder and associated plumbing connections including the hydraulic hoses.

A periodic inspection of this device must be conducted according to the recommendation in the maintenance schedule.

4.7 - SLOPE WARNING DEVICE

From each control box, a buzzer alerts the operator that the machine is not folded/stowed and is positioned on a slope exceeding the slope allowed.

N.B.-:-THE SLOPE SENSOR IS ONLY ACTIVE WHEN THE PLATFORM IS NOT IN THE STOWED POSITION.

When machine is on a slope greater than the rated slope, with extending structure out of the stowed position :

- The DRIVE and LIFTING (RAISING) commands are deactivated.

The lowering speed is reduced.

In this case, fully fold the machine and place it on an authorized slope.

To check the tilt sensor at ground level, perform the following steps :

Daily check

Step	Action
1	Put the machine in stowed position on a slope with an angle greater than the permitted inclination (Refer to  Section B 4.1 Technical specifications).
2	• Check that the "tilt" (14) indicator is lit up

C - Pre-operation inspection

4.8 - TRAVEL SPEED LIMITATION

The machine has a selector of 3 driving speeds - low, medium and high.

All driving speeds are authorised when the machine is folded, (machine in transport position).

The maximum travelling speeds are reduced when the following lifting height is reached :

Machine	Maximum platform height before driving speed restriction	
	Mètre	Feet
HS 15 E (HS 4390 E)	2,95 m	9 ft 8 in
HS 15 E PRO (HS 4390 E PRO)	2,95 m	9 ft 8 in
HS 18 E (HS 5390 E)	2,95 m	9 ft 8 in
HS 18 E PRO (HS 5390 E PRO)	2,95 m	9 ft 8 in

When not in the above-described transport position, the low speed is engaged automatically.

The electronic variable speed unit controls movement and driving speed.

It receives information from the control joystick concerning the movements to be performed.

It also manages the safety systems status.

Poor knowledge of the characteristics and operation of the machine can lead the operator to think that a normal safety operation is a malfunction.

On a slope, the speed decreases automatically.

4.9 - ON-BOARD ELECTRONICS

The machine is equipped with a specific calculator configured for this machine's functionalities.

Do not interchange the Calculator (calibration restoration) between machines..

D - Operation instructions

1 - Operation

1.1 - INTRODUCTION

Only trained and authorized personnel shall be permitted to operate this aerial work platform.

Prior to operation :

- Read, understand and obey all instructions and safety precautions in this manual and attached to the aerial work platform.
- Read, understand and obey all local regulations.
- Become familiar with the proper use of all controls and emergency systems.

1.2 - MAJOR DESCRIPTION

All the machines are equipped with :

- Platform control box.
- Ground control box (Overriding system).

1.3 - OPERATION FROM THE GROUND CONTROL BOX

- Turning "ON" and "OFF" of the machine is performed with selector key switch (21).
- Activation of a desired control box is achieved by turning the control box energizing selector switch (21) to the desired position.
- The ground control box is energized and is active ONLY when :
 - The emergency stop on the ground control box is not pushed in.
 - Ground control box is selected.
- An EMERGENCY STOP button located on each control box stops all movements and shuts off the engine when pressed in.
- An Enable Switch (6) provided must be activated and maintained to authorize one or more function movements. If Enable Switch (6) is kept engaged without selecting a function movement for more than 8 s; Enable Switch is automatically de-activated.
- Only movements of lifting and lowering the platform are possible from the ground control box.
- All switches and joystick operating a movement, return automatically to neutral when released.
- Overriding system : The ground control box is an auxiliary control box to use in emergencies only. Refer to  Section D 4.2 - To rescue operator in platform.
- The status of the switches is tested automatically when the machine is switched on. A switch will be active only after it has been detected to be in neutral position. The following switches are not controlled :
 - Beacon light (if fitted)

D - Operation instructions

- Engine speed (If fitted) : This switch increases the engine rpm to the maximum speed.
- A buzzer beeps in the following conditions :
 - When power is switched on.
 - Overload.
 - Slope if machine is out of stowed position.
 - Hydraulic oil overheating.
 - Movement buzzer option.
 - Drive buzzer option.
- Indicators : All indicators are checked after powering on the machine

1.4 - OPERATION FROM THE PLATFORM CONTROL BOX

- The platform control box can only be used if :
 - The E-stop buttons on both ground and platform control boxes are not pressed in.
 - Platform control box selected from ground control box.
- A faulty joystick is not taken into account to control a movement. If this fault disappears, the movement is authorised again.
- An E-Stop button is present at each control box. When pushed in, it stops all functions movements.
- The release of "Enable switch" (31) while performing a movement stops all the movements. The stop of movements is progressive. It could restart only when the selected function switch/joystick is released to neutral position.
- All switches and joystick operating a movement, return automatically to neutral when released.
- The status of the switches and joysticks is tested automatically when the machine is switched on. A switch or joystick will be active only after it has been detected in neutral position.

A buzzer beeps in the following conditions :

- Overload.
- Machine elevated on a slope greater than the rated slope.
- Indicators : All indicators are checked after powering on the machine.

D - Operation instructions

2 - Ground control box

2.1 - TO START AND STOP THE MACHINE

- Check that the E-stop buttons (9) at ground control box and (1) at platform control box are not pressed in.
- Turn the control box selector (21) to position  to energize the ground control box. Full Electric mode (18) is activated by default

If the activation key selector for the control box (21) is activated, the machine is in Full Electric mode by default. Refer to the section on operating modes 

Mode operation

To shut-down the machine from the ground control box :

- Turn the activation selector key switch (21) to off position .
- Power supply is now switched off.

N.B.-:-THIS OPERATION TURNS OFF THE POWER SUPPLY TO MACHINE AND IT IS REQUIRED TO PREVENT BATTERY DISCHARGE.

D - Operation instructions



2.2 - MOVEMENT CONTROL



Even at low movement speeds, use the controls with caution.

N.B.-:RELEASING THE ENABLE SWITCH WILL STOP ALL MOVEMENTS.

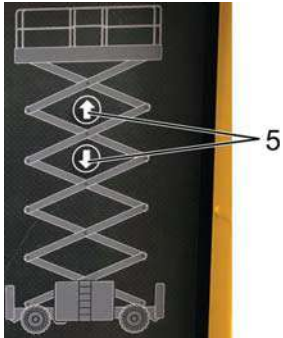
Ground box controls (emergency station)

Command	Action
<p>Platform raising / lowering</p> 	<p>Push the platform raising / lowering selector (5) upwards to raise the platform.</p> <hr/> <p>Press the platform raising / lowering selector (5) downwards to lower the platform.</p> <hr/> <p>Note : To activate these movements, the activation command  must be pressed and held simultaneously.</p>

2.3 - ADDITIONAL CONTROLS

For the machines equipped with flashing light :

- Press the beacon light selector switch (14) to turn ON the beacon light.
- Press the beacon light selector switch (14) to turn OFF the beacon light.

D - Operation instructions

3 - Platform control box

3.1 - TO START AND STOP THE MACHINE

3.1.1 - To start the machine

At the ground control box :

- Check that the E-stop button (9) is not pressed in.

- Turn the control box activation key selector (21) to platform control box position  to switch on the platform control box.

At the platform control box :

- Check that the E-stop button (1) is not pressed in.
- The power on indicators (20, 21) on the platform's display panel light up.

If the activation key selector for the control box (21) is activated, the machine is in Full Electric mode by default. Refer to the section on operating modes : Mode operation.

3.1.2 - To stop the engine

The engine stops and the machine returns to Full Electric mode if :

- In MANUEL (19) mode or AUTO (22) mode, the selector (21) on the platform control box is activated

The machine's power supply can only be turned OFF from the ground control box by turning the control box activation key selector (21) to the OFF  position (Mode operation).

D - Operation instructions









3.2 - DRIVE AND STEER CONTROL



To select the Drive/Steering function, choose the movement speed (25, 26, 27). Push the joystick (33) and the Enable Switch (31) to perform the movements (Except for stabilizing movements).







Do not use simultaneously the differential lock control (30) and the steering control.

Command		Action
Driving		Move the drive joystick forwards to drive the machine forwards.
		Move the drive joystick backwards to drive in reverse.
Front-axle steering		Push the front-axle steering selector thumb switch to the right to steer to the right.
		Push the front-axle steering selector thumb switch to the left to steer to the left.
Drive speed		Position the drive speed selector switch (25) on  for high-speed driving.
		Position the driving speed selector (26) on  for medium speed driving (crossing uneven ground, slope).
		Position the driving speed selector (27) on  for low-speed driving (short distance, final approach, unloading from lorries/trucks).

N.B.--RELEASING THE ENABLE SWITCH (31) AND/OR DRIVE JOYSTICK (33) STOPS THE MOVEMENT.

D - Operation instructions

Outriggers controls

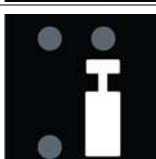
Command		Action
Stabilizer extension/retraction		Push the central stabilizer extension/retraction selector (4) downwards until the machine is stable (LED lit).
		Push the central stabilizer extension/retraction selector (4) upwards until the stabilizers are fully retracted (LED off).
Front left stabilizer extension/retraction		Push the front left stabilizer extension/retraction selector (2) downwards until the stabilizer is braced against the ground (LED lit).
		Push the front left stabilizer extension/retraction selector (2) upwards until the stabilizer is fully retracted (LED off).
Front right stabilizer extension/retraction		Push the front right stabilizer extension/retraction selector (3) downwards until the stabilizer is braced against the ground (LED lit).
		Push the front right stabilizer extension/retraction selector (3) upwards until the stabilizer is fully retracted (LED off).
Rear left stabilizer extension/retraction		Push the rear left stabilizer extension/retraction selector (6) downwards until the stabilizer is braced against the ground (LED lit).
		Push the rear left stabilizer extension/retraction selector (6) upwards until the stabilizer is fully retracted (LED off).
Rear right stabilizer extension/retraction		Push the rear right stabilizer extension/retraction selector (5) downwards until the stabilizer is braced against the ground (LED lit).
		Push the rear right stabilizer extension/retraction selector (5) upwards until the stabilizer is fully retracted (LED off).

N.B.-:-THE RELEASE OF THE SELECTORS AND (OR) JOYSTICKS CAUSES ALL MOVEMENT TO STOP.

D - Operation instructions

3.3 - MOVEMENT CONTROL

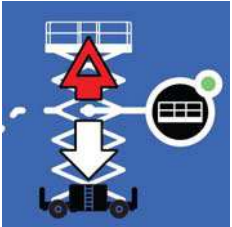

To select the Raising command, choose the movement speed (25, 26, 27). Push the joystick (33) and the Enable Switch (31) to perform the movements.

Command		Action
Platform raising / lowering		<p>Push the platform raise/lower touch pad (12). Push the movement joystick (33) backwards to raise the platform.</p> <hr/> <p>Push the platform raise/lower touch pad (12). Push the movement joystick (33) forwards to lower the platform.</p>

3.4 - ADDITIONAL CONTROLS

- Horn : Press the Horn switch (28) to sound the horn. The horn stops when the selector switch is released.

3.4.1 - Activ' Lighting System

Refer to  Section B 3.3 - Platform control box.

The system Activ' Lighting System illuminates the controls and the surrounding area of the machine. Users can then safely move the machine.

D - Operation instructions

4 - Rescue and emergency procedures

4.1 - IN CASE OF POWER LOSS

In the event of power loss, control system failure or other malfunction, platform lowering functions may be accomplished manually.

In an emergency, if the operator has to exit the platform while it is elevated, the transfer of the operator must respect the following recommendations :

- Exit onto a sturdy and safe structure.
- The occupant(s) must ensure that 2 lanyards are used for security/safety. One must be attached to the designated anchorage point on platform the occupant(s) is in and the other attached to the structure intended to get on.
- Occupant(s) must exit the current platform through the normal access.

N.B.-:DO NOT DETACH THE LANYARD FROM THE CURRENT PLATFORM IF THE TRANSFER TO THE NEW STRUCTURE POSES ANY DANGER OR UNTIL THE TRANSFER IS SAFELY COMPLETED. DO NOT TRY TO GET OFF THE PLATFORM BY GRIPPING THE GUARDRAILS. WAIT FOR HELP TO GET OFF THE PLATFORM SAFELY.

D - Operation instructions

4.2 - TO RESCUE OPERATOR IN PLATFORM



In a situation where an operator located in the platform needs to be rescued (for example in case of illness, injury or trapped against a structure making the control box inaccessible), the rescue personnel at ground level needs to obtain rapid and direct access to operating functions.

HAULOTTE® has implemented a control system for safely lowering the operator to the ground in the event of an emergency to enable him to receive the necessary treatment.



The system allows occupant(s) to be lowered to the ground level, even if an E-Stop is engaged or if an overload is detected.

Procedure :

- Turn the ground control box key control (21) to the ground control box  position.
- The platform box controls are now de-energized.
- Check that the E-Stop button (9) at ground is not pressed in.
- To lower the platform, hold down the Enable Switch (6)  and simultaneously activate the desired control function (5) .

D - Operation instructions



4.2.1 - Operation of overriding system from ground control box

N.B.-:IF THE SAFETY SYSTEMS DO NOT ALLOW NORMAL MOVEMENT FROM THE GROUND CONTROL BOX, OR IN THE EVENT OF OVERHEATING, USE THE OVERRIDING SYSTEM DESCRIBED BELOW.



Operation of the "overriding system" switch must be an exception and not a normal emergency operation.

Procedure :

- Press and hold the "overriding" system control (11) .
- Press the platform raise / lower control (5)  to raise or  lower the platform.

N.B.-:ONCE RESCUE OPERATIONS ARE COMPLETE, WRITE AN INCIDENT REPORT. OVERRIDING SYSTEM MUST BE RESET BY A HAULOTTE SERVICES® TECHNICIAN.

D - Operation instructions

4.3 - NO POWER AVAILABLE

Should the electrical controls or main power fail, it is possible to operate directly on the distributor using a mechanical lever.

4.3.1 - Manual emergency lowering procedure

V a l v e



- Actuate the lever (1).
- Pull the handle (2) to open the lower console case .



D - Operation instructions

- Use the lever (3) located in the hood .

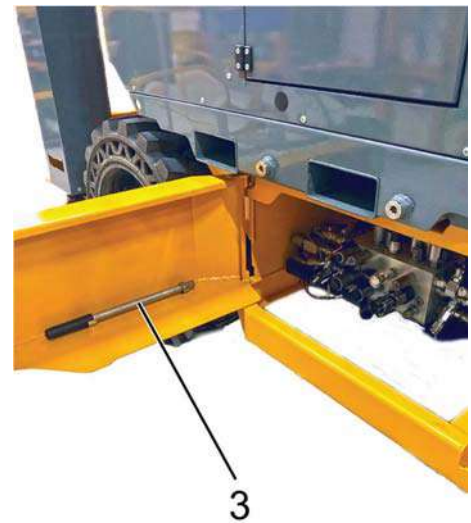

- Insert the lever (3) in the return bend of the pump (4).
- Strongly press and hold the button (5).
- Push the pump lever (3) until you feel resistance. The platform lowering speed is now proportional to the pump operating speed.
- Watch the platform and its surroundings continuously.
- Stop actuating lever (3) and keep button (5) in position until the platform is completely lowered.

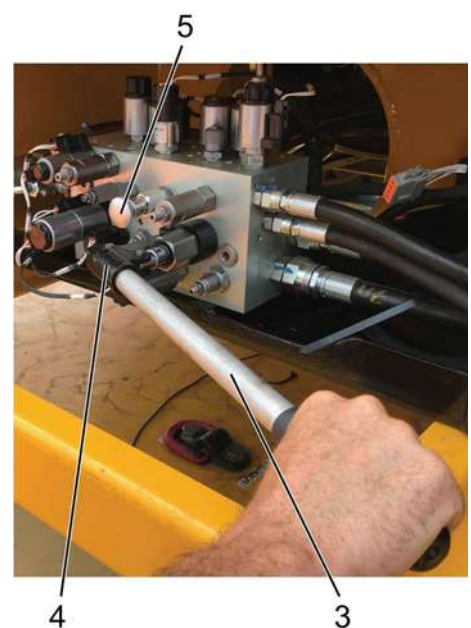

N.B.-:-IF BUTTON (5) IS RELEASED WHEN THE PLATFORM IS LOWERED, ALL MOVEMENT WILL BE INTERRUPTED AND IT WILL BE NECESSARY TO RESTART THE EMERGENCY LOWERING OPERATION.



Quick and jerky pump operation could lead to rapid lowering, and create a risky situation. Before and during each manoeuvre, ensure that there are no obstacles or people near the platform.

D - Operation instructions

5 - Transportation

5.1 - TRANSPORT CONFIGURATION



During loading, ensure that :

- The loading ramp can support the machine weight.
- The loading ramp is correctly attached to transport vehicle.
- The loading ramp has sufficient grip surface.
- The transport vehicle must be parked on a level surface and must be secured to prevent rolling away while machine is being loaded or unloaded.

To climb the slope, move progressively the drive joystick .

If the slope is too steep, use a winch in addition to traction.

Do not place yourself below or too close to the machine during loading.

The machine must be completely in the stowed configuration :

- Check the platform is completely empty.
- Platform extension must be retracted in the locked position.
- Drive the machine onto the truck bed.
- Secure the machine to the tie down points provided (See picture).



The manual extension (if fitted) must be retracted and locked during transport or towing.

The guardrails must be locked and/or folded inwards.



Danger : RISK OF CRUSHING FOLLOWING AN UNEXPECTED MOVEMENT :

- Ensure that the machine is not on a slope and place a shim in front of the wheels in all cases before releasing the brakes.
- After towing the machine with the brakes released, before uncoupling the towed machine, place the safety shims in front of the wheels and reset the valve to “pushed in” configuration, otherwise the brakes will not be applied.

D - Operation instructions

5.2 - MACHINE STORAGE FOR TRANSPORT - HS15 E (HS4390 E) - HS15 E PRO (HS4390 E PRO) - HS18 E (HS5390 E) - HS18 E PRO (HS5390 E PRO)

HS 15 E (HS 4390 E) - HS 15 E PRO (HS 4390 E PRO) - HS 18 E (HS 5390 E) - HS 18 E PRO (HS 5390 E PRO)

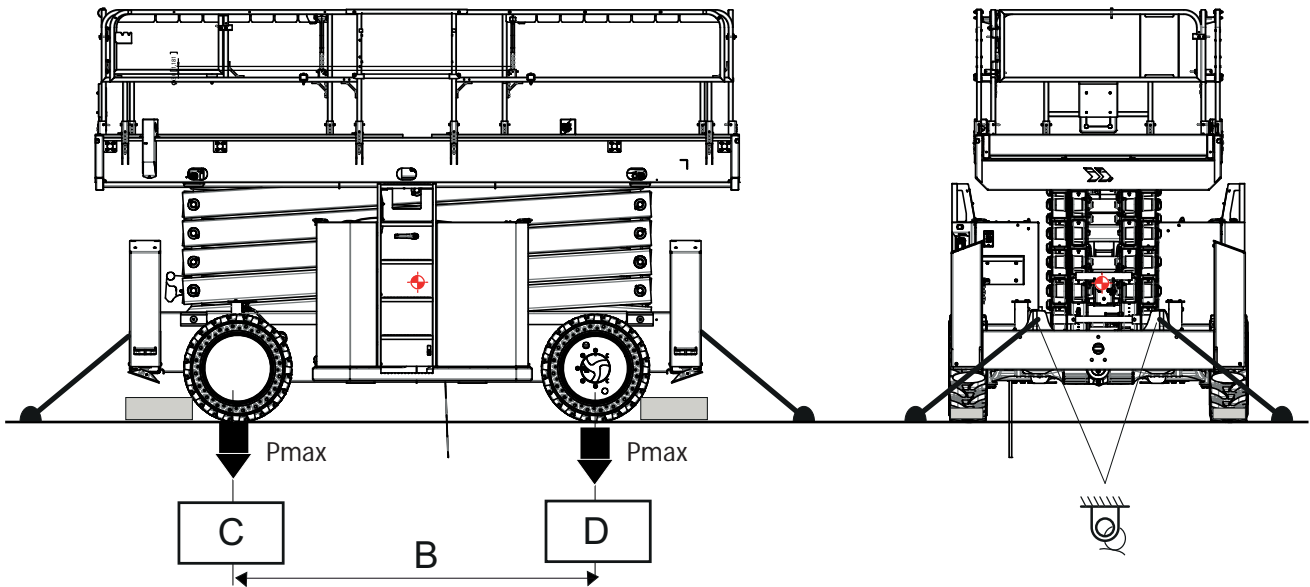

Loading characteristics

Marking	Description	HS15 E - HS4390 E	HS15 E PRO- HS4390 E PRO
B	Lateral distance between the wheels	2.755 m(9 ft0 in)	
C	Front wheel ground pressure	15,7 daN/cm ² (3,28 lbf/sq.ft)	
D	Rear wheel ground pressure	15,7 daN/cm ² (3,28 lbf/sq.ft)	
	Anchorage point		

Loading characteristics

Marking	Description	HS18 E - HS5390 E	HS18 E PRO - HS5390 E PRO
B	Lateral distance between the wheels	2.755 m(9 ft0 in)	
C	Front wheel ground pressure	15,7 daN/cm ² (3,28 lbf/sq.ft)	
D	Rear wheel ground pressure	15,7 daN/cm ² (3,28 lbf/sq.ft)	
	Anchorage point		

D - Operation instructions

5.3 - LOADING BY RAMP



To avoid any risk of sliding during loading, ensure that :

- The loading ramp can bear the load.
- The loading ramp is correctly attached.
- The loading ramp has sufficient grip.
- The machine is completely stowed.



To climb the slope, select low driving speed .



- Never place yourself below or too close to the machine during loading.
- A wrong move can lead to the tipping over of the machine and cause serious bodily and material accidents.

5.4 - FOLDING GUARDRAILS

5.4.1 - Description

Folding guardrails system is designed to allow guardrails to be lowered to reduce the overall height of the machine.

This system facilitates moving the machine through low height doorways/passages.

5.4.2 - Safety precautions



- Place the machine on flat ground.
- Fully lower the platform to the stowed position.
- Take care to avoid trapping the hands while folding the guardrails.
- User must wear gloves.
- Keep hands clear of pinch points.
- Squat down when moving to avoid falling.

5.4.3 - Fold down operation

- Extension deck must be fully retracted and in locked position.
- The intermediate sliding entrance bar must be at its lowest position.



D - Operation instructions

Remove the platform control box from its starting position and set it aside in a safe place.

N.B.:-THE PROCEDURE FOR FOLDING DOWN THE GUARDRAILS IS THE SAME WHETHER THE MACHINE HAS THE SUPPORT ACTIV' SHIELD BAR SCISSOR OR NOT.



Whichever guardrail is to be folded down, the operator must always be positioned in the centre of the guardrail before folding it down.



- Remove the lock pins as it folds down.
- Hold the guardrail that is to be folded down by hand to prevent it from falling over abruptly.

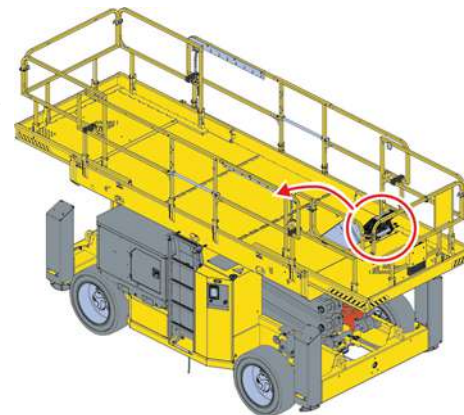

Order of folding for the guardrails, extensions retracted

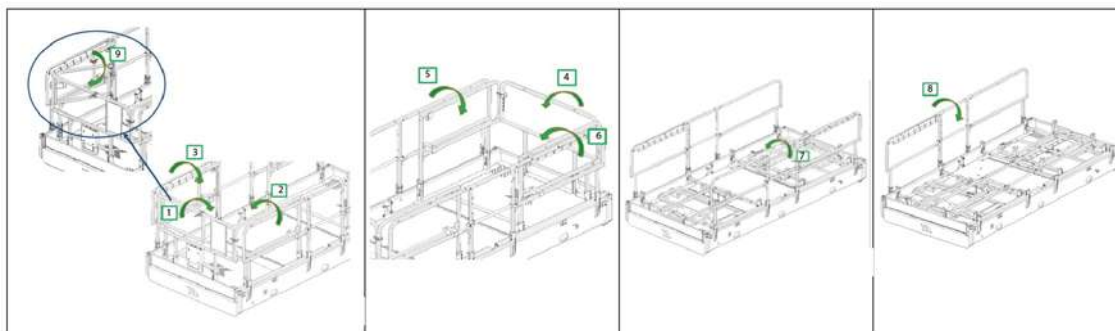

D - Operation instructions

Guard rail front extension (1)

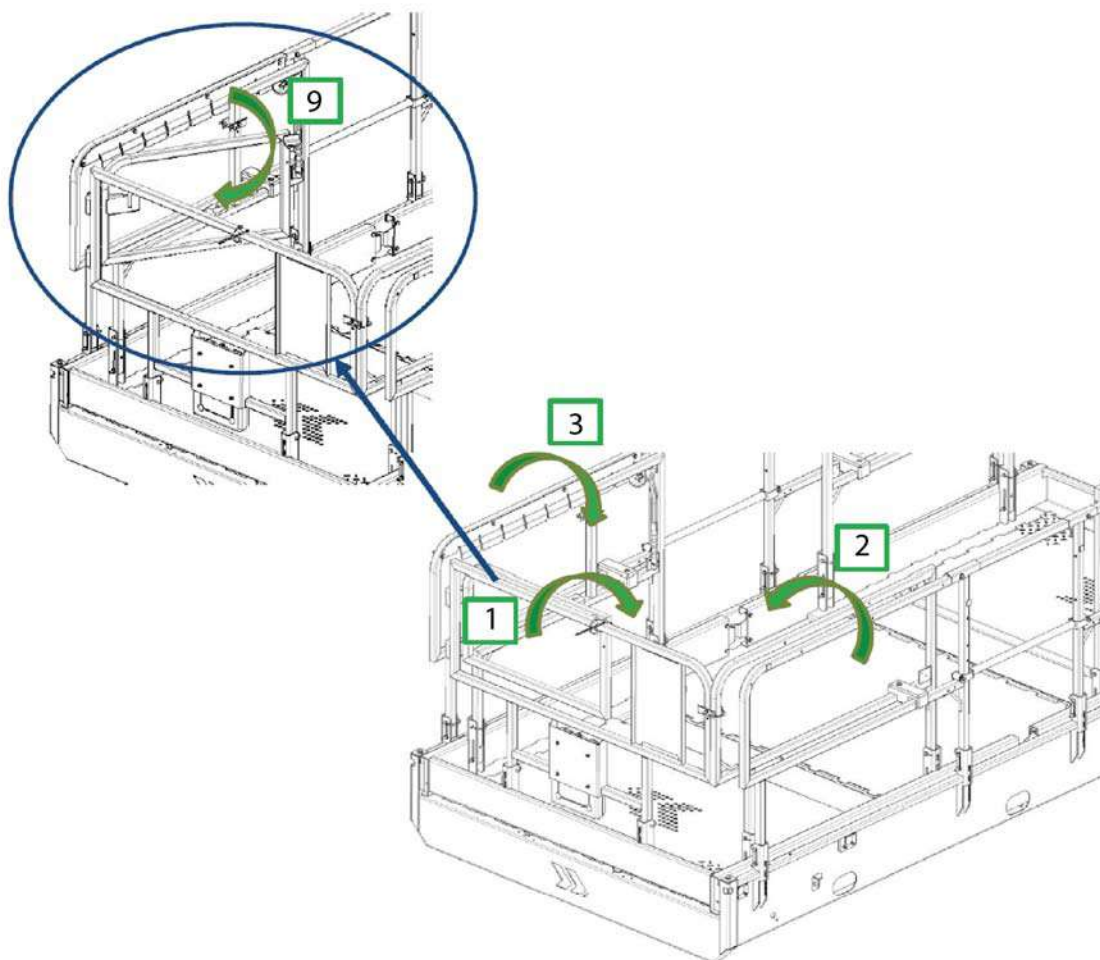

Support Activ' Shield Bar Scissors :

- Fold the support (9) on the front guard rail (1).
- Fit the pin (10) in place.

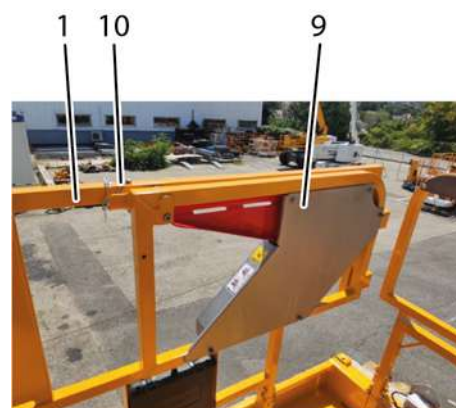

D - Operation instructions

Front guardrail (1) :

- Remove the pin .
- Lift the fixing clip (11).



- Remove the 2 pins (12).

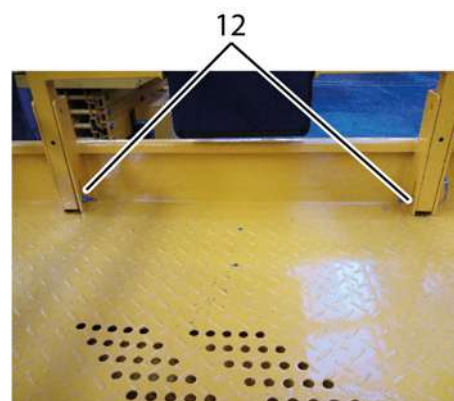

- Fold the front guardrail (1).

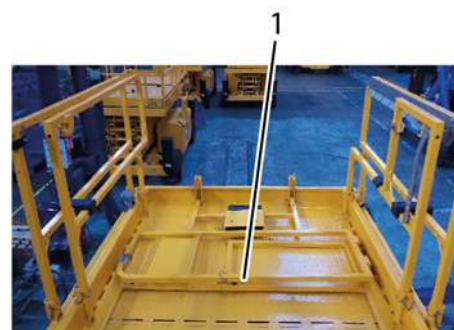

D - Operation instructions

Front left guard rail (2) :

- Remove the 2 pins (13).

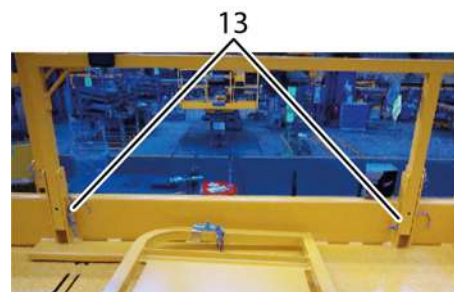

- Fold the front left guard rail (2).

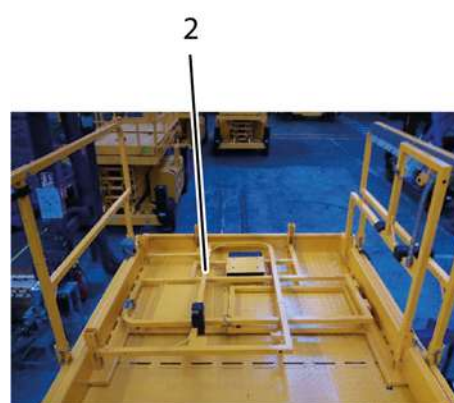

Front right guard rail (3) :

- Remove the 2 pins (14).

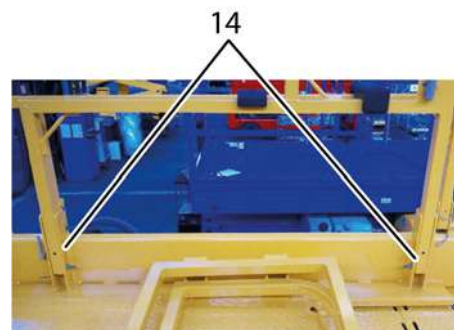

- Fold the front right guard rail (3).

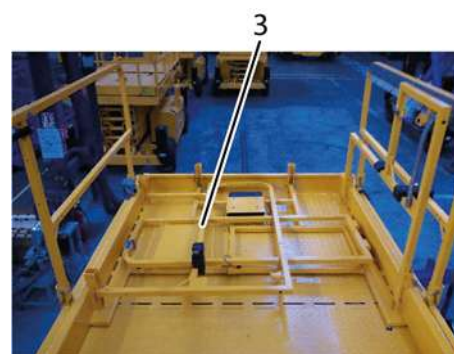

D - Operation instructions

Guard rail rear extension (4)

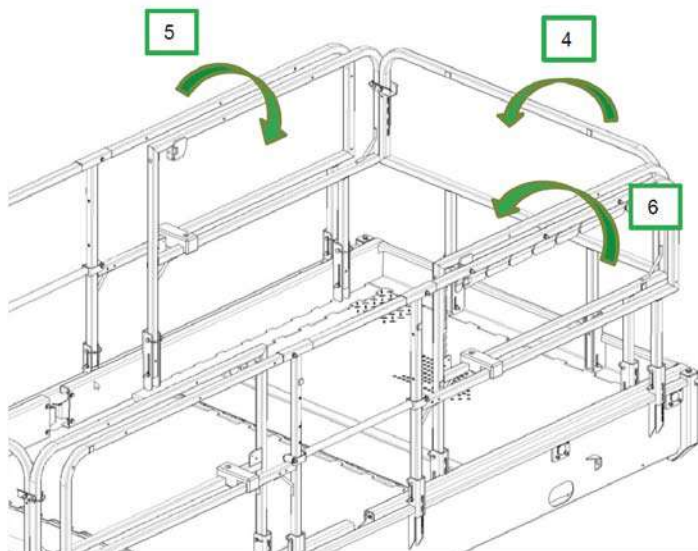

Rear guard rail (4) :

- Remove the 2 pins .
- Lift the 2 fixing clips (15).

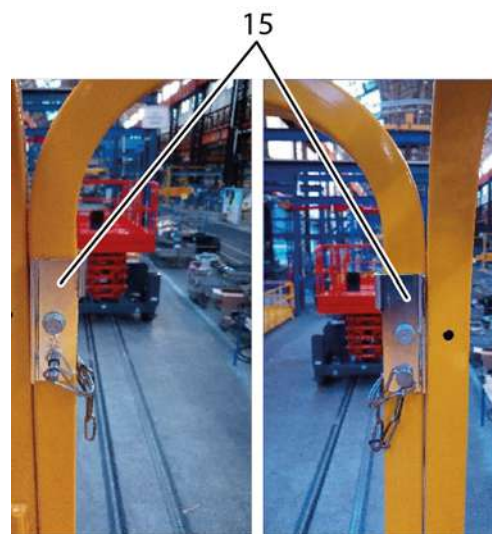

- Remove the 2 pins (16).

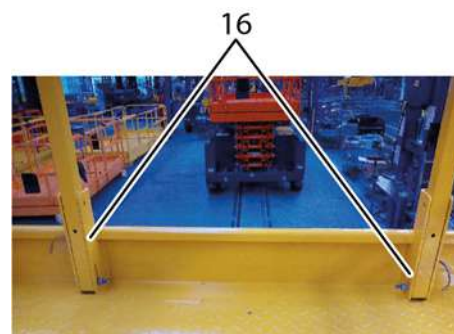

D - Operation instructions

- Fold the rear guard rail (4).



Rear left guard rail (5) :

- Remove the 2 pins 17.

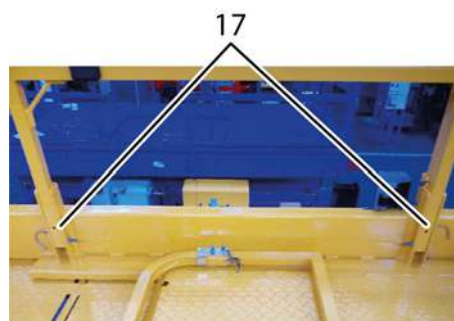

- Fold the rear left guard rail (5).

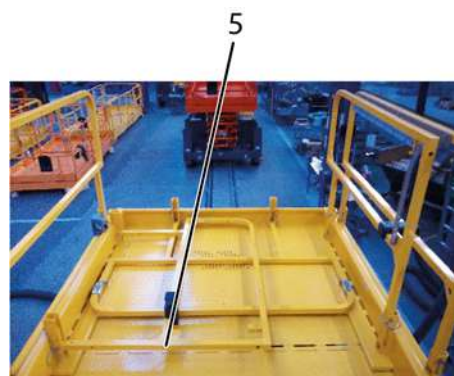

Rear right guard rail (6) :

- Remove the 2 pins 18.

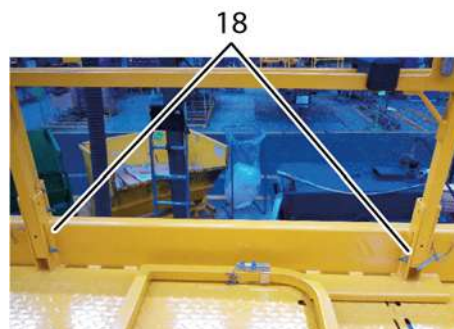

D - Operation instructions

- Fold the rear right guard rail (6).

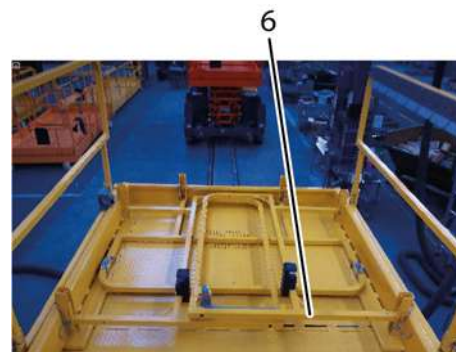

Left side guard rail (7)

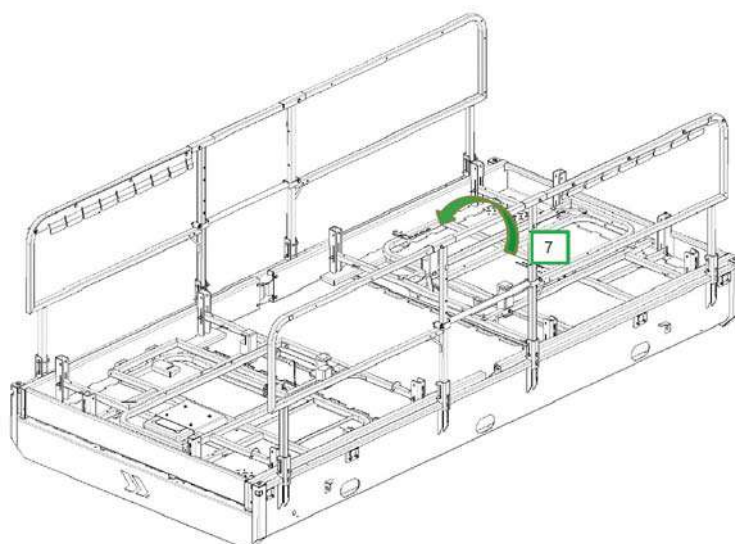

- Remove the 4 pins (19).

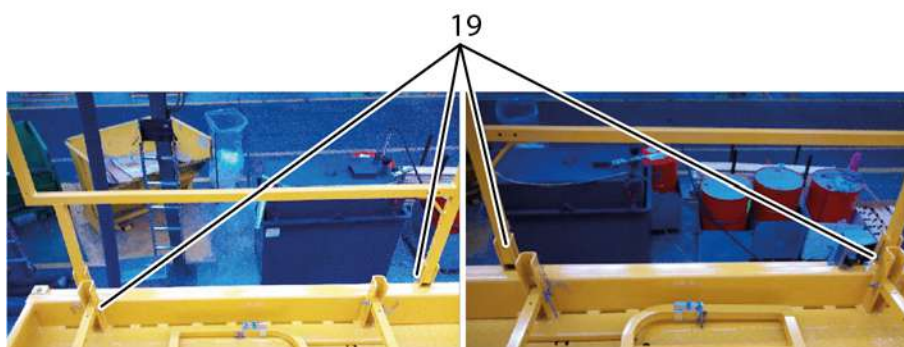

D - Operation instructions

- Fold the left side guard rail (7)

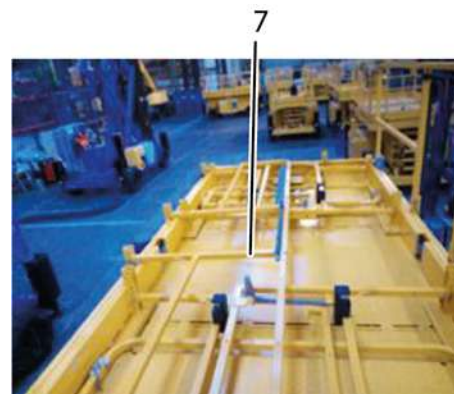

Right side guard rail (8)

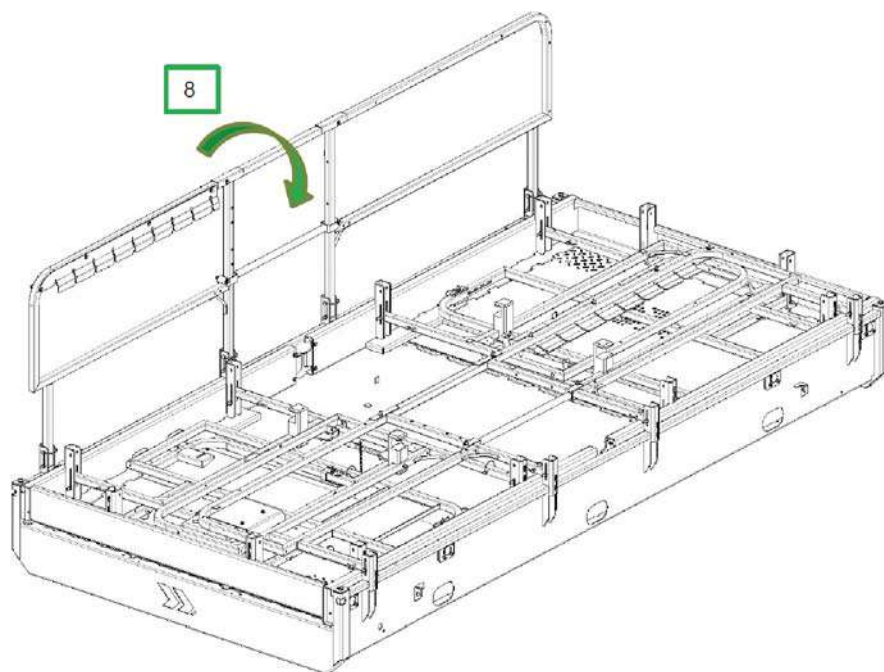

- Remove the 4 pins 20.

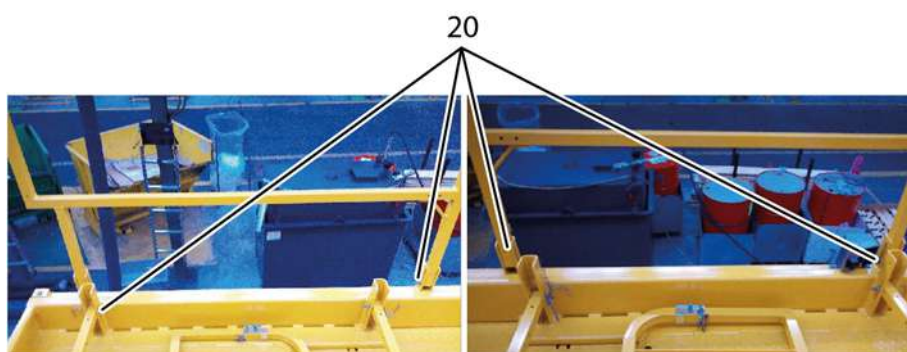

D - Operation instructions

- Fold the right side guard rail (8)



5.4.4 - Raising guardrails to working position

To raise the folded guardrails to the vertical working position :

- Follow the fold down operational sequence in the reverse order.
- Ensure all pins are installed and secured.



Do not use the machine if the pins are missing, damaged or not approved by HAULOTTE®

D - Operation instructions

5.5 - UNLOADING

Before unloading, check that the machine is in good condition.

- Remove the tie downs.
- Pull the E-Stop buttons (9) at ground control box and (1) on the platform control box.
- On the lower control panel, turn the key switch (21) to position  to activate the upper control panel.
- Select low drive speed at the platform control box.
- On the platform control box, press and hold the activation switch (31) while gently and progressively moving the drive joystick (33).



Warning : Upon starting a machine that has been secured and transported, the safety system may detect a false overload preventing all movement from the platform control box.

To reinstate the system, lift the platform a few centimetres (inches) from the ground control box.

5.5.1 - Unloading by ramp



Before operating, check that the machine is in good condition.

If the machine has been damaged during transportation, contact the transporter in writing.

1. The machine is completely stowed.
2. Remove the tie downs.
3. Start the machine.
4. The ramp is in good condition and of sufficient capacity.



Do not travel down the ramp at a fast speed.

D - Operation instructions

5.6 - TOWING



In the event of a machine breakdown, the machine can be towed a short distance to load it onto a transport vehicle :

- Lock-out the machine (Refer to the Service Manual MS0163 - Lock-out procedure).
- Ensure that no one is in the platform during towing.
- Before towing, ensure that the platform is fully lowered.
- The platform must be empty.
- **ALWAYS** keep personnel and obstructions clear of the aerial work platform when brakes are released.

To tow a broken-down machine, release brake (Refer to : Brake release).

Perform this operation on flat ground with wheels chocked.

In the towing configuration, the machine braking system is inactive. Use a drawbar to avoid any risk of accident :

- Do not exceed the maximum speed (machine unfolded) (Refer to  Section B 4.1 - Technical specifications).



To go up or down a slope, use the appropriate winch.

A

B

C

D

E

F

G

H

I

D - Operation instructions

5.6.1 - Brake release

To tow a broken-down machine, perform manual brake release.



Perform these operations on flat, horizontal ground. Block the wheels to immobilize the machine. The machine is in free wheel mode, so the braking system is not active.



Use manual control ONLY to tow the machine.

The brake release valve is located just above the rear axle :

- Press hard on the end of the valve (red part) and simultaneously turn it through a 1/4 turn (clockwise).



- Open the cover above the ground control box.
- Take the lever to insert in the distributor.



D - Operation instructions

- Insert the lever (1) in the return bend of the pump (2)
- Actuate lever (3) sideways until a constant resistance force is felt (15 to 20 actions on the lever (1) are usually required)

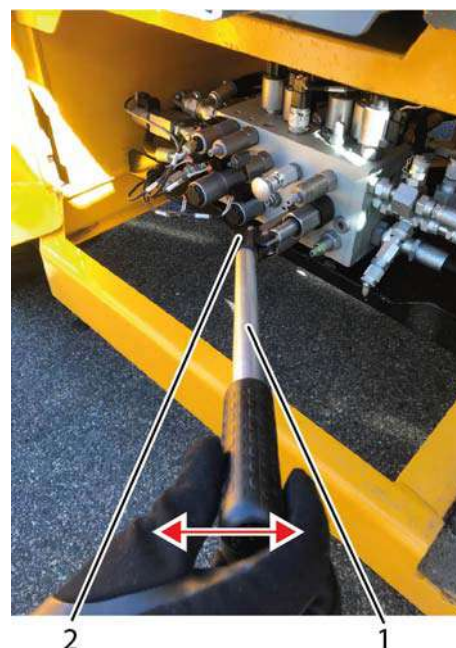

From Haulotte Diag : Check that the pressure is higher than 30 bar(435 psi) : :

- "Diagnostic" menu (Accessible with level 1 code)
- "Machine status" menu (Accessible with level 1 code)
- "Brake release" menu (Accessible with level 1 code)

N.B.-:-IF THE PRESSURE DROPS BELOW 25 BAR(362 PSI) DURING TOWING, ACTUATE LEVER (2) AGAIN SO THAT THE PRESSURE RETURNS TO ABOVE 30 BAR(435 PSI)

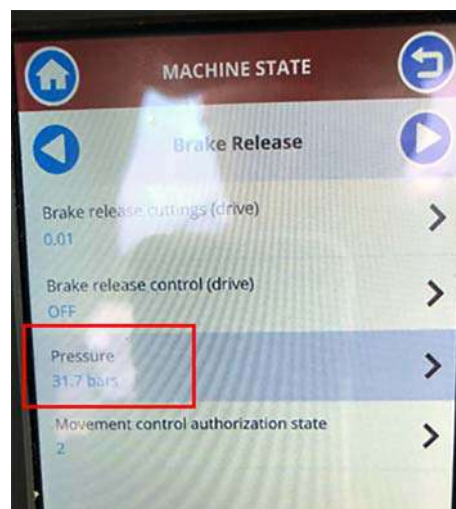

D - Operation instructions

As soon as the machine is towed to a safe, stable position, the parking brake must be immediately reactivated by unlocking the brake release valve :

- Remove the lever (1) from the return bend of the pump (2).
- Press hard on the end of the valve (red part) and simultaneously turn it through a 1/4 turn (anti-clockwise).

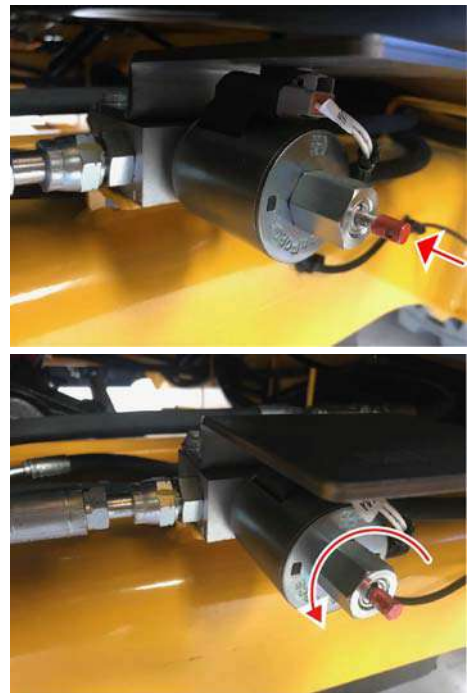

In the towing configuration, the machine is no longer slowed down. Use a drawbar to avoid any risk of accident.



Do not exceed the maximum speed (machine unfolded) (Refer to  Section B 4.1 - Technical specifications).

D - Operation instructions

5.7 - STORAGE



The machine can be stored in a designated area when not in use. If it is stored for more than 3 months without being used, an inspection must be carried out before it is put back into service.



- For engine storage condition follow engine supplier operator and maintenance manuals.
- Keep the batteries charged  Section D 7.4 Optimise battery life.

Do not store or immobilise the machine when it is unfolded.

Ensure all access panels, doors and side compartment covers are shut and secured.

- Turn the energizing key selector switch (21) at the ground control box to the "center" position to shut OFF the power.
- Remove the ignition key to prevent unauthorized operation of the machine.



To avoid any risk of corrosion on rods of cylinders during a storage period of more than 1 month :

- In a normal atmospheric environment : perform a complete cycle for the cylinders every 2 months while they are in storage.
- In harsh environments (high levels of salinity in the atmosphere: close to the sea, industrial environment with chloride emissions and/or humidity >70%), we recommend applying the following protection process :
 - Wash and rinse the entire machine with plenty of clean water.
 - Dry all the cylinder rods using an air gun.
 - Apply a solvent-based oil leaving an oily film after evaporation of the solvent directly to all rods left exposed when the machine is in storage position.
 - Re-apply the product every month.



After washing the machine, make sure it is fully air-dry and does not contain moisture on corrosive parts (cylinders rods for example).

Do not wash any electrical components, particularly with high pressure washer. Wipe away dirt from around electrical components with a dry cloth.

A

B

C

D

E

F

G

H

I

D - Operation instructions

5.8 - LIFTING OPERATION

During loading / unloading operation with an overhead crane, it is important to respect the following :

- Put the machine in stowed position.
- Platform must be empty.
- Verify that lifting accessories are in good operation and match the technical specifications listed below. It is important that the lifting devices are attached only to the designated lifting eyes.
- Each of the slings used for lifting the machine must be adjusted to keep the machine level and to minimize the risk of damage to the machine.



- Anchorage point for lifting are identified / labeled by the following symbol .
- ONLY trained and authorized personnel should attempt to lift the machine.

5.8.1 - Procedure for the use of slings HS15 E (HS4390 E) - HS15 E PRO (HS4390 E PRO) - HS18 E (HS5390 E) - HS18 E PRO (HS5390 E PRO)

Machine type	Maximum weight
HS15 E (HS4390 E) - Standard platform + 1 extension	7 362 kg (16,230 lbs)
HS15 E (HS4390 E) -Standard platform + 2 extensions	7 518 kg (16,574 lbs)
HS15 E (HS4390 E) -Large platform + 2 extensions	7 648 kg (16,860 lbs)
HS15 E PRO (HS4390 E PRO) -Standard platform + 2 extensions	7 518 kg (16,574 lbs)
HS15 E PRO (HS4390 E PRO) -Large platform + 2 extensions	7 648 kg (16,860 lbs)
HS18 E (HS5390 E) - Standard platform + 1 extension	7 902 kg (17,420 lbs)
HS18 E (HS5390 E) -Standard platform + 2 extensions	8 048 kg (17,742 lbs)
HS18 E (HS5390 E) -Large platform + 2 extensions	8 178 kg (18,029 lb)
HS18 E PRO (HS5390 E PRO) -Standard platform + 2 extensions	8 048 kg (17,742 lbs)
HS18 E PRO (HS5390 E PRO) -Large platform + 2 extensions	8 178 kg (18,029 lbs)



The machine must be fully folded, with platform extensions retracted and locked.

D - Operation instructions

Attach 4 shackles of at least 5000 kg / 11,025 lb with the straps (5 m / 16 ft 5 in - 5000 kg / 11,025 lb) minimum to the 4 chassis rings.



Attach the slings using shackles.



Ensure that the shackles are correctly locked.



Check that the rings do not catch on the ground jacks and the platform.



D - Operation instructions



The machine must be handled very slowly.



Pass the slings inside the guardrails to avoid damaging them.

Marking	Description
A	4 straps 5 m (16 ft 5 in) 5 T and 4 shackles 5 T between machine and crane

D - Operation instructions

6 - Cold Weather Recommendations

In cold weather, do not store the machine with discharged batteries. It is recommended that, at a temperature below 0 °C(32 °F) , the machine not be stored with a battery charge of below 75 %. If you don't have a power outlet, start the engine in Forced Mode with the generator, to increases the battery's state of charge.

Set to Manual mode to start the engine to check that it is operating correctly. If the engine does not start, do not keep trying for a prolonged period of time. Allow the starter to cool down for a few minutes before trying again. If the engine still does not start after several attempts, consult the maintenance manual and switch to Full Electric mode.

In extreme cold conditions, machines should be equipped with optional cold start kits.

N.B.-:INITIAL STARTING SHOULD ALWAYS BE PERFORMED FROM THE GROUND CONTROL BOX.

6.1 - HYDRAULIC OIL

External environmental conditions can reduce performance of the machine if the hydraulic oil temperature does not reach its optimum range.

It is recommended to use the hydraulic oil according to weather condition. Refer to the table below.

Environmental conditions	SAE Viscosity grade
Ambient temperature between - 15°C (5°F) and + 40°C (+ 104°F)	HV 46
Ambient temperature between - 35°C (- 31°F) and + 35°C (+ 95°F)	HV 32
Ambient temperature between 0°C (+ 32°F) and + 45°C (+ 113°F)	HV 68

N.B.-:IT IS RECOMMENDED TO REPLACE LOW TEMPERATURE OIL AS THE AMBIENT TEMPERATURE REACHES + 15°C (59°F). IT IS NOT ADVISABLE TO MIX OILS OF DIFFERENT BRANDS OR TYPES.

D - Operation instructions

7 - Battery care and maintenance

7.1 - LOCATIONS

- Actuate the lever (1)
- Pull the handle (2) to open the battery box



Marking	Description
3	On-board charger
4	Batteries

D - Operation instructions



Marking	Description
5	Battery charger mains cable

D - Operation instructions

7.2 - BATTERY RECHARGE

7.2.1 - On-board charger

The on-board charger is used to charge the semi-drive batteries. The charger's power is 3000W and the maximum intensity is 16A for 220V - 240V and 110V networks. Battery charging starts as soon as it is connected via the mains supply.

N.B.:-NO MOVEMENTS ARE ALLOWED DURING BATTERIES CHARGING CYCLE AND WHILE CONNECTED TO AN EXTERNAL POWER OUTLET.

Battery charger	48V / 60A
Electric power supply	265-85 Vac / 50-60hz / 16A
Battery voltage	48 V
Charging time	Between 12 h and 24 h(except option Range Extender)



Never replace the charging cable without written permission from HAULOTTE®.

7.2.2 - Battery charging



- Do not use an external charger or jump the batteries.
- Ensure the mains supply is compatible ;
- Do not use a cable reel with the cable wound up.
- The cable cross-section must be at least 2,5 mm² or more, depending on the length of the cable.
- The socket must be able to deliver a current of 16 A.
- If the power supply does not have the necessary power, a limited charging power can be selected from Haulotte Diag (Accessible with level 1 code).

D - Operation instructions

**M a c h i n e s e t t i n g s / M a c h i n e c o n f i g u r a t i o n /
O p t i o n s e t t i n g / B a t t e r y c h a r g e c o n f i g u r a t i o n
/ S i n g l e - p h a s e**



D - Operation instructions

Machine settings / Machine configuration / Option setting / Battery charge configuration / Three-phase

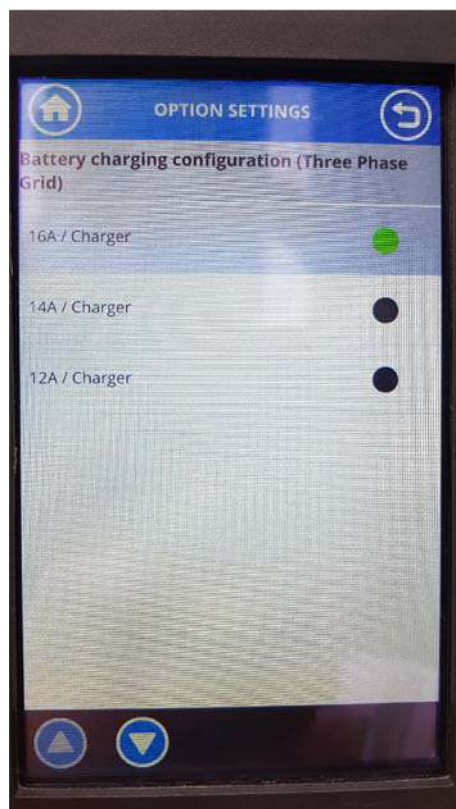

- Do not charge the battery when the outside temperature is -20°C .
- ALWAYS charge batteries in open, well-ventilated areas.
- You are advised to fully charge the battery at least 1 time every 7 days.

Duration of charge cycle :

- 12 hours approximately, on 220 - 240 V AC network.
- 20 hours approximately, on 110 V AC network.

The charge cycle stops automatically when charging is complete.

It can take up to 24 hours for a full charge if the battery levels are very low (Charge status less than 5 %) ; except option Range Extender

D - Operation instructions

7.3 - BATTERY CARE AND MAINTENANCE

7.3.1 - Filling batteries



The batteries must **ONLY** be filled after charging them fully. Failure to comply with these instructions may lead to the electrolyte overflowing, etc...



The batteries **MUST** be filled when necessary or the batteries may be irreparably damaged. The lead plates oxidize in the air. They must always be covered with electrolyte.



The water level in the batteries cannot be topped up if the temperature is lower than 0° as the distilled or deionized water freezes in the centralized filling system.

Single - Point Watering System

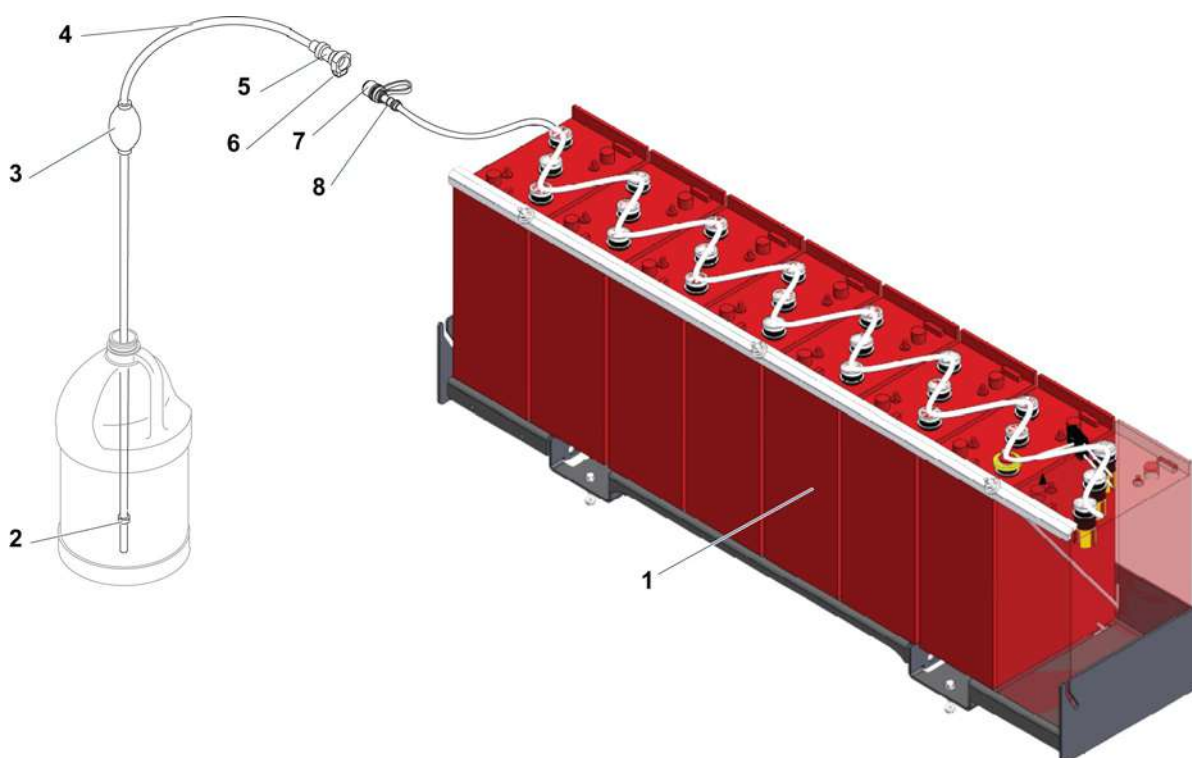

Marking	Description
1	Batteries
2	Filtered intake
3	Hand pump
4	Hose
5	Female adapter
6	Push-button
7	Dust cover
8	Male adapter

Completely charge the batteries before connecting the distilled-water-filling unit.

D - Operation instructions

Procedure to fill the batteries manually



Levelling of the elements should always be done after charging the batteries. Watering a battery before charge (or with a low charge level) can lead to boil-over, resulting in potential bodily injury and potential damage to the watering system and the battery.

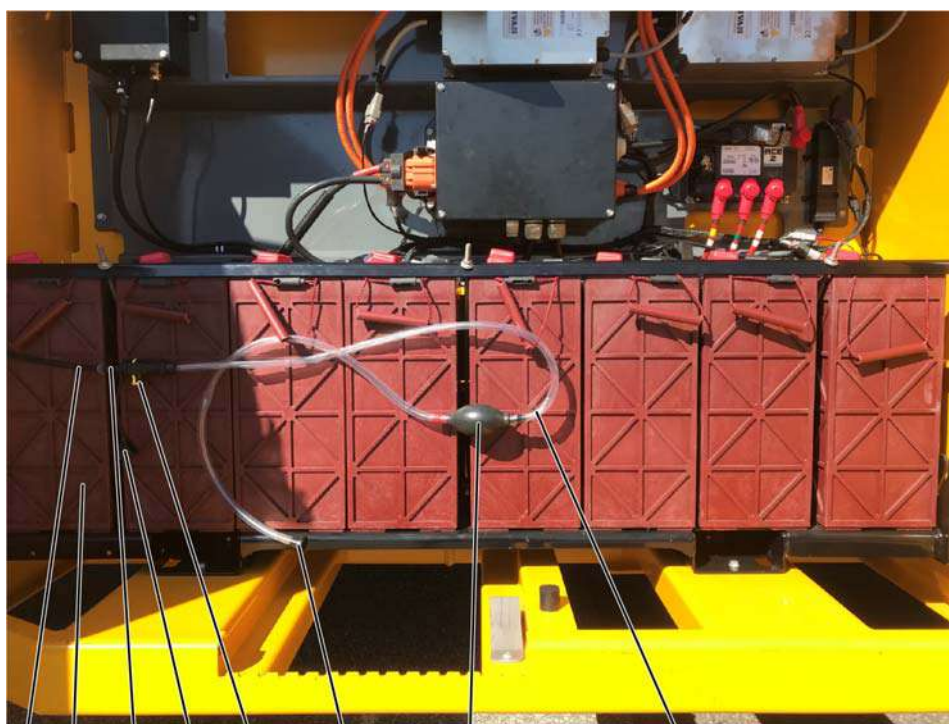

8 1 6 7 5 2 3 4

1. Launch a full charge of the battery and check the charge indicator.
2. Disconnect the batteries charger and put back the plug in its housing.
3. Accessing batteries. (Refer to section : Battery care and maintenance)
4. Immerse the filtered inlet (2) of the transparent hose (4) fitted with a hand pump (3) in a demineralized water canister(Not supplied with the machine).
5. Press the hand pump (3) to prime it until the water rises in the hose (4)
6. Once the hand pump (3) is primed, remove the male connector (8) cap (7) from the black supply tube assembly
7. Connect the female connector (5) quick-hitch from the centralized filling system, including the hand-pump, to the male connector (8).
8. Press firmly on the hand pump to bring the distilled water to the batteries (1).
9. When the bulb (3) becomes resistant, this means that all the battery cells are filled appropriately.
10. Then uncouple the female connector (5) from the male connector (8) filling tube by pressing on the yellow button (6), then replace the cap (7) on the machine hose.
11. Close the machine covers.
12. Do not let the can to connect after filling is finished because this could cause the batteries to overflow.

D- Operation instructions

Procedure to fill the batteries automatically – Option



To perform centralized battery refilling, the outside temperature must not be below 0 ° C.

1. Accessing batteries. (Refer to section : Battery care and maintenance)
2. Loosen the filling cap (1).
3. Fill the can with demineralized water.
4. Refit the filling plug again.
5. Close the machine covers.
6. Fully recharge the batteries in order to restart automatic filling or activate automatic filling from Haulotte Diag.

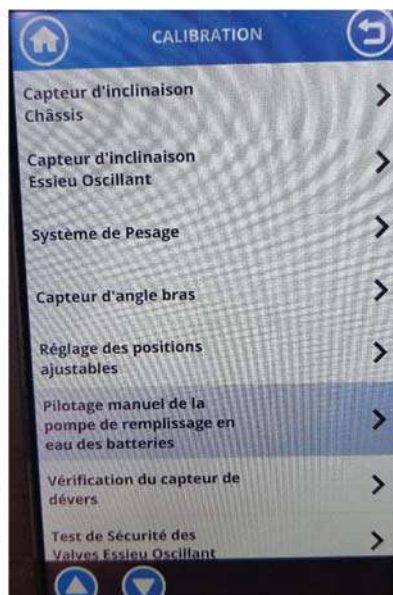
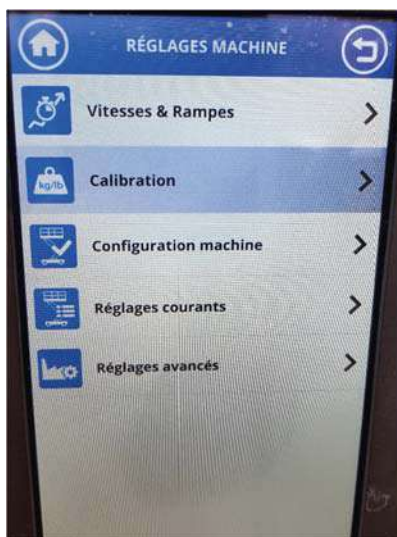

D - Operation instructions

7.3.2 - Desulfation charge

Normal battery use leads to sulfation of the lead plates during discharge (Formation of lead sulfate). Recharging the battery dissolves the lead sulfate. The plates are desulfated.

Moreover, sulfation also appears if the battery self-discharges during storage in a low state-of-charge (< 70%).

As the battery ages, the lead sulfate may become harder and harder and increasingly difficult to eliminate by normal charging. This leads to a loss of autonomy. The desulfation charge is a way of regenerating the battery.



To improve the efficiency of the desulfation charge, you are advised to launch it for a battery discharged to a state-of-charge less than 30%.

Procedure :

- Go to the machine set-up menu → Option → Desulfation request (Code HAULOTTE DIAG level 2) ;
- The option is active and will be implemented during the next mains charge ;
- Charging time is increased up to 72 h ;

A

B

C

D

E

F

G

H

I

D - Operation instructions

7.4 - OPTIMISE BATTERY LIFE

To optimize battery performance and life-time, you are advised to follow the recommendations below :

- Carry out regular battery maintenance as described.
- Do not store the machine discharged (Duration greater than 72 hours)
- Carry out full charges regularly.
- Do not keep a machine in a state-of-charge less than 70% for no useful purpose
- **A full battery recharge is OBLIGATORY every 35 hours of use of the machine.**
- **After 45 hours of use without a full recharge, there is a risk of damaging the batteries.**



Keep the top of the batteries clean and dry. Incorrect connection or corrosion may cause a high loss of power.

	Full charge	Filling control	Desulfation charge
In use			
As soon as possible	X		
If state-of-charge < 50% at the end of a working day	X		
Every 35 hours of use	X		
Before placing in storage	X		
1 time a week	X	X	
1 time every 6 months			X
In storage			
1 time a month	X		



In case of extended storage, you are advised to fully charge the battery then disconnect the power circuit. Charging the battery monthly is still recommended.



The battery's water consumption depends on its use. You are advised to check the water level 1 time a week.

E - General Specifications

1 - Machine dimensions

Stowed / Transport position : Configuration that takes the minimum floor space necessary for storage and / or delivery of the machine -
Access position - HS15 E (HS4390 E) - HS15 E PRO (HS4390 E PRO) - HS18 E (HS5390 E) - HS18 E PRO (HS5390 E PRO)

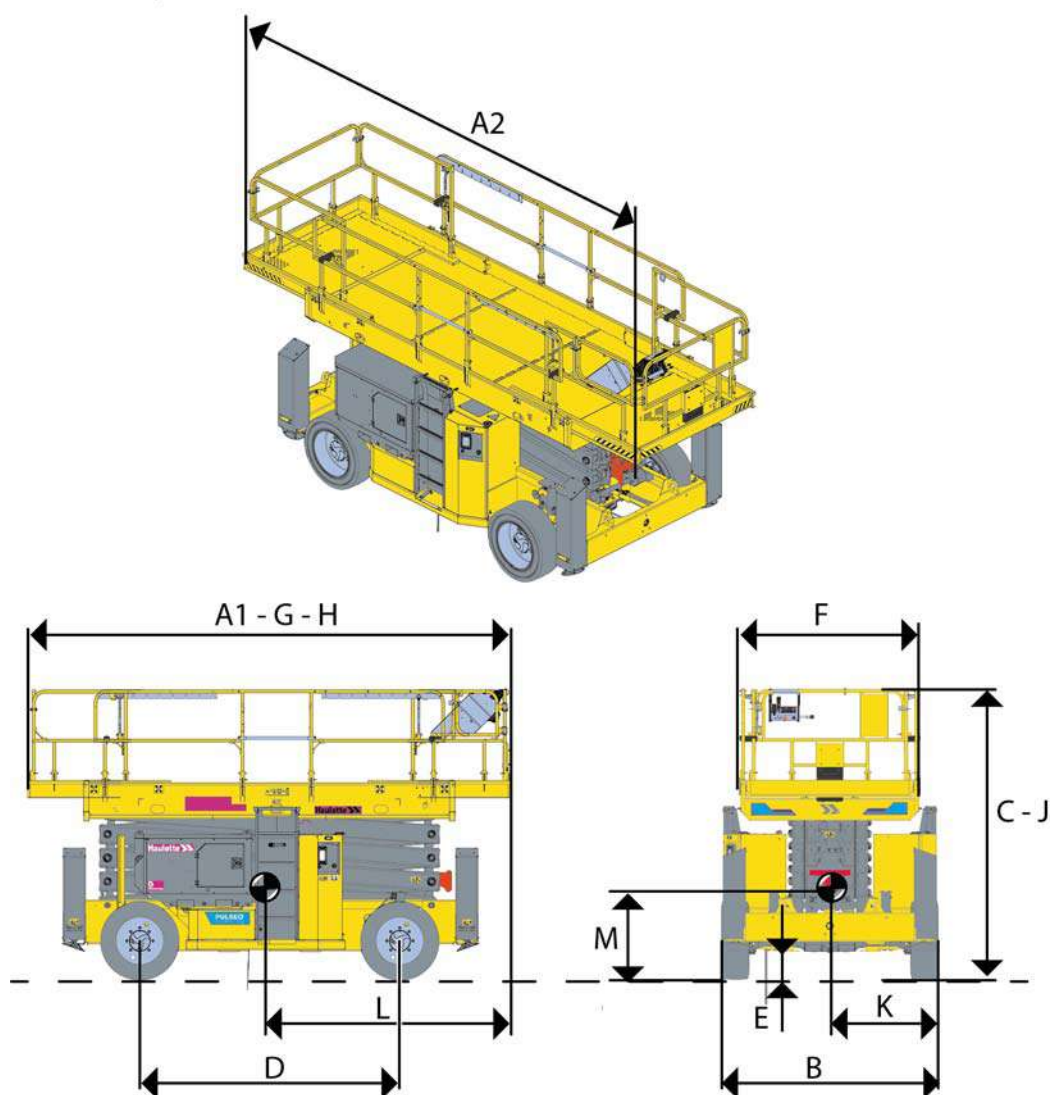

E - General Specifications

Overall dimension specifications

Machine		HS15 E (HS4390 E)		HS18 E (HS5390 E)	
		Standard platform + 1 extension			
Marking	Specifications - Dimensions	SI	Imp.	SI	Imp.
A1 - H	Overall length of machine (Closed extension) - Storage length	4,405 m	12 ft 5 in	4,405 m	12 ft 5 in
A2	Overall length of machine (Extensions extended)	4,907 m	16 ft 1 in	4,907 m	16 ft 1 in
B	Overall width of machine	2,300 m	7 ft 7 in	2,300 m	7 ft 7 in
C - J	Overall height of machine - Storage height	3,050 m	10 ft	3,150 m	10 ft 4 in
D	Wheel base	2,755 m	9 ft	2,755 m	9 ft
E	Ground clearance	30 cm	13 in	30 cm	13 in
F x G	Platform dimensions	1,890 m x 3,820 m	6 ft 2 in x 12 ft 6 in	1,890 m x 3,820 m	6 ft 2 in x 12 ft 6 in
K	Center of gravity - X	1,19 m	3 ft 11 in	1,19 m	3 ft 11 in
L	Center of gravity - Y	1,95 m	6 ft 5 in	1,93 m	6 ft 6 in
M	Center of gravity - Z	1,98 m	6 ft 4 in	1,07 m	3 ft 5 in
	Outside turning radius	6,450 m	21 ft 2 in	6,450 m	21 ft 2 in
	Inside turning radius	3,600 m	9 ft 10 in	3,600 m	9 ft 10 in

Overall dimension specifications

Machine		HS15 E (HS4390 E) - HS15 E PRO (HS4390 E PRO)		HS18 E (HS5390 E) - HS18 E PRO (HS5390 E PRO)	
		Standard platform + 2 extensions			
Marking	Specifications - Dimensions	SI	Imp.	SI	Imp.
A1 - H	Overall length of machine (Closed extension) - Storage length	4,405 m	12 ft 5 in	4,405 m	12 ft 5 in
A2	Overall length of machine (Extensions extended)	5,887 m	19 ft 4 in	5,887 m	19 ft 4 in
B	Overall width of machine	2,300 m	7 ft 7 in	2,300 m	7 ft 7 in
C - J	Overall height of machine - Storage height	3,050 m	10 ft	3,150 m	10 ft 4 in
D	Wheel base	2,755 m	9 ft	2,755 m	9 ft
E	Ground clearance	30 cm	13 in	30 cm	13 in
F x G	Platform dimensions	1,890 m x 3,820 m	6 ft 2 in x 12 ft 6 in	1,890 m x 3,820 m	6 ft 2 in x 12 ft 6 in
K	Center of gravity - X	1,19 m	3 ft 11 in	1,19 m	3 ft 11 in
L	Center of gravity - Y	1,95 m	6 ft 5 in	1,93 m	6 ft 6 in
M	Center of gravity - Z	1,98 m	6 ft 4 in	1,07 m	3 ft 5 in
	Outside turning radius	6,450 m	21 ft 2 in	6,450 m	21 ft 2 in
	Inside turning radius	3,600 m	9 ft 10 in	3,600 m	9 ft 10 in

E - General Specifications

Overall dimension specifications

Machine		HS15 E (HS4390 E) - HS15 E PRO (HS4390 E PRO)		HS18 E (HS5390 E) - HS18 E PRO (HS5390 E PRO)	
		Large platform + 2 extensions			
Marking	Specifications - Dimensions	SI	Imp.	SI	Imp.
A1 - H	Overall length of machine (Closed extension) - Storage length	4,954 m	16 ft 3 in	4,954 m	16 ft 3 in
A2	Overall length of machine (Extensions extended)	7,508 m	24 ft 8 in	7,508 m	24 ft 8 in
B	Overall width of machine	2,300 m	7 ft 7 in	2,300 m	7 ft 7 in
C - J	Overall height of machine - Storage height	3,050 m	10 ft	3,150 m	10 ft 4 in
D	Wheel base	2,755 m	9 ft	2,755 m	9 ft
E	Ground clearance	30 cm	13 in	30 cm	13 in
F x G	Platform dimensions	1,890 m x 3,820 m	6 ft 2 in x 12 ft 6 in	1,890 m x 3,820 m	6 ft 2 in x 12 ft 6 in
K	Center of gravity - X	1,19 m	3 ft 11 in	1,19 m	3 ft 11 in
L	Center of gravity - Y	1,95 m	6 ft 5 in	1,93 m	6 ft 6 in
M	Center of gravity - Z	1,98 m	6 ft 4 in	1,07 m	3 ft 5 in
	Outside turning radius	6,450 m	21 ft 2 in	6,450 m	21 ft 2 in
	Inside turning radius	3,600 m	9 ft 10 in	3,600 m	9 ft 10 in

E - General Specifications

2 - Major component masses

N.B.: -MASSES MEASURED WITH EMPTY TANKS.

Specifications	HS15 - HS4390	
	E	E PRO
Frame assembly mass	3640 kg (8,024 lbs)	3640 kg (8,024 lbs)
Scissors assembly mass	2920 kg (6,437.5 lbs)	2920 kg (6,437.5 lbs)
Standard platform assembly mass + extension 1	812 kg (1,790 lbs)	Not applicable
Standard platform assembly mass + 2 extensions	958 kg (2,112 lbs)	958 kg (2,112 lbs)
Wide platform assembly mass + 2 extensions	1088 kg (2,398 lbs)	1088 kg (2,398 lbs)
Mass of one wheel	145 kg (319 lbs)	145 kg (319 lbs)
Bare battery mass	440 kg (970 lbs)	440 kg (970 lbs)

Specifications	HS18 - HS5390	
	E	E PRO
Frame assembly mass	3640 kg (8024 lbs)	3640 kg (8024 lbs)
Scissors assembly mass	3450 kg (7605 lbs)	3450 kg (7605 lbs)
Standard platform assembly mass + extension 1	812 kg (1,790 lbs)	Not applicable
Standard platform assembly mass + 2 extensions	958 kg (2,112 lbs)	958 kg (2,112 lbs)
Wide platform assembly mass + 2 extensions	1088 kg (2,398 lbs)	1088 kg (2,398 lbs)
Mass of one wheel	145 kg (319 lbs)	145 kg (319 lbs)
Bare battery mass	440 kg (970 lbs)	440 kg (970 lbs)

E - General Specifications

3 - Acoustics and vibrations

The acoustics and vibrations specifications are based upon the following conditions :

- The airborne noise emissions at workstation are determined per European Directive 2006/42/CE.
- The guaranteed sound power level LWA (displayed on the product) is determined per European Directive 2000/14/CE.
- The vibrations transmitted by the machinery to the hand/arm system and to the whole body are determined per European Directive 2006/42/CE.

Specifications	
Sound pressure level at workstation — Without Range Extender	< 70 dBA
Sound pressure level at workstation — With Range Extender	< 102 dBA
Vibrations hand/arm	Vibration transmitted by this MEWP to the hand-arm does not exceed 2,5 m/s ² (98,4 in/s ²)
Vibrations whole body	Vibration transmitted by this MEWP to the whole body does not exceed 0,5 m/s ² (19,6 in/s ²)

E - General Specifications

4 - Wheels

4.1 - TECHNICAL SPECIFICATIONS

Component	Standard wheel HS15 E (HS4390 E) - HS15 E PRO (HS4390 E PRO) - HS18 E (HS5390 E) - HS18 E PRO (HS5390 E PRO)
Reference number	Solideal 830 x 285
Type	Solid Tyre (Curred - on)
Wheel mass	145 kg (319.67 lbs)
Size	830 mm / 285 mm – 2 ft 7 in / 0 ft 9 in
Torque hub	320 Nm (236 ft lbs)

4.2 - INSPECTION AND MAINTENANCE



The tire and rim are bonded together, both must be replaced if either is damaged.

Wheels replacement must be made in the following cases :

- Deformation or cracks on the rim.
- De-bonding between the interface of the steel and the rubber.
- Uniform wear to the wearing line :
- 830 x 285 wheel : \varnothing 830 mm / 33 in



- Non-linear wearing of the tread profile (> 10%)

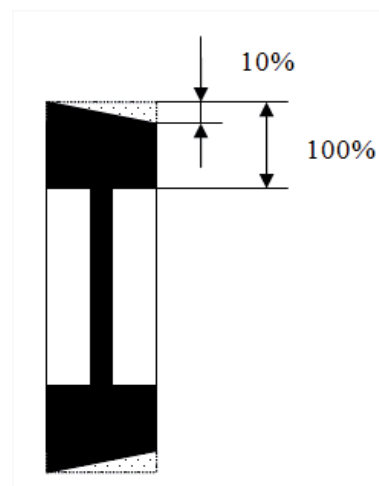

A

B

C

D

E

F

G

H

I

E- General Specifications

- Linear wear of the thread profile (> 25 %)

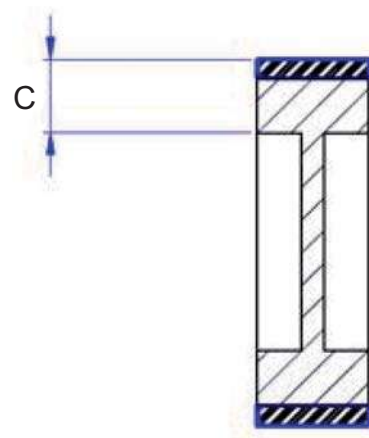

	Standard wheel HS15 E (HS4390 E) - HS15 E PRO (HS4390 E PRO) - HS18 E (HS5390 E) - HS18 E PRO (HS5390 E PRO)
New tire	C = 140 mm / 6 in
Defective tire (Linear wear of the tread profile > 25 %)	C = 105 mm / 5 in

- 1 wheel stud is completely torn.
- 2 successive wheel studs are partially torn.
- 2 aperture holes are cut.



Tires and rims are critical components for the stability of the machine. For safety reasons :

- Use only HAULOTTE® spare parts according to the technical characteristics of the machine. Refer to the spare parts catalog.
- Do not replace factory-installed tires with tires of different specifications or ply rating.
- Never replace a solid (rigid) tire with a foam-filled or a pneumatic (air-filled) tire.

E - General Specifications

Procedure of replacement :

- Loosen the wheel nuts on the wheel to be removed.
- Raise the machine using a jack or a hoist.
- Remove the wheel nuts.
- Remove the wheel.
- Install the new wheel.
- Lower the machine to the ground.
- Tighten the wheel nuts evenly to the torque of 320 Nm (236 ft lbs).



Check the tightening torque of the wheel nuts every 200 h of operation

N.B.:-IF A WHEEL HAS BEEN REPLACED, LOOK AT THE DIRECTION OF THE CLAMPS (WHICH INDICATES ROTATION IN THE AV DIRECTION) TO MAKE SURE IT IS CORRECTLY INSTALLED

A

B

C

D

E

F

G

H

I

E - General Specifications

5 - Options

5.1 - ACTIV'SHIELD BAR SCISSORS - SECONDARY GUARDING SYSTEM (IF THE FUNCTION IS PRESENT AND THE DEVICE IS INSTALLED IN ITS SUPPORT)

5.1.1 - Description



General Specification Activ'Shield Bar Scissors :

- The Activ'Shield Bar Scissors system is a device designed to reduce the risk of crushing against the control console and guardrail when the platform moves into confined spaces.
- This device is complementary to the existing operator protection including the enable switch system (Trigger of joystick, Foot Switch and Enable Switch on platform control box).
- The Activ' Shield Bar Scissors system is activated when the console is in its support and when :
 - The platform is rising
 - The platform rises and reverses
- The Activ'Shield Bar Scissors system is inactive when the upper control console is not in its support.
- The green indicator light of the Activ'Shield Bar Scissors is illuminated indicating the device is active.
- Light flashing : Activ'Shield Bar Scissors active with a potentially dangerous movement in progress.
- Indicator not illuminated : The Activ'Shield Bar Scissors system is inactive







This system does not relieve the operator from the responsibilities of learning and practicing the principles of safe use and operation of the machine as provided by the manufacturer's instructions, employer's safety rules and worksite regulations



If the console is not in its support, the high speed functions are deactivated

Summary of the indicator states

	System is inactive, all Activ'Shield Bar Scissors related safety are OFF
	System is active and a potentially dangerous movement is selected
	System is active and a potentially dangerous movement is running
	System is active and the bar is crushed. Specific movement cuts apply

E - General Specifications

5.1.2 - Characteristics

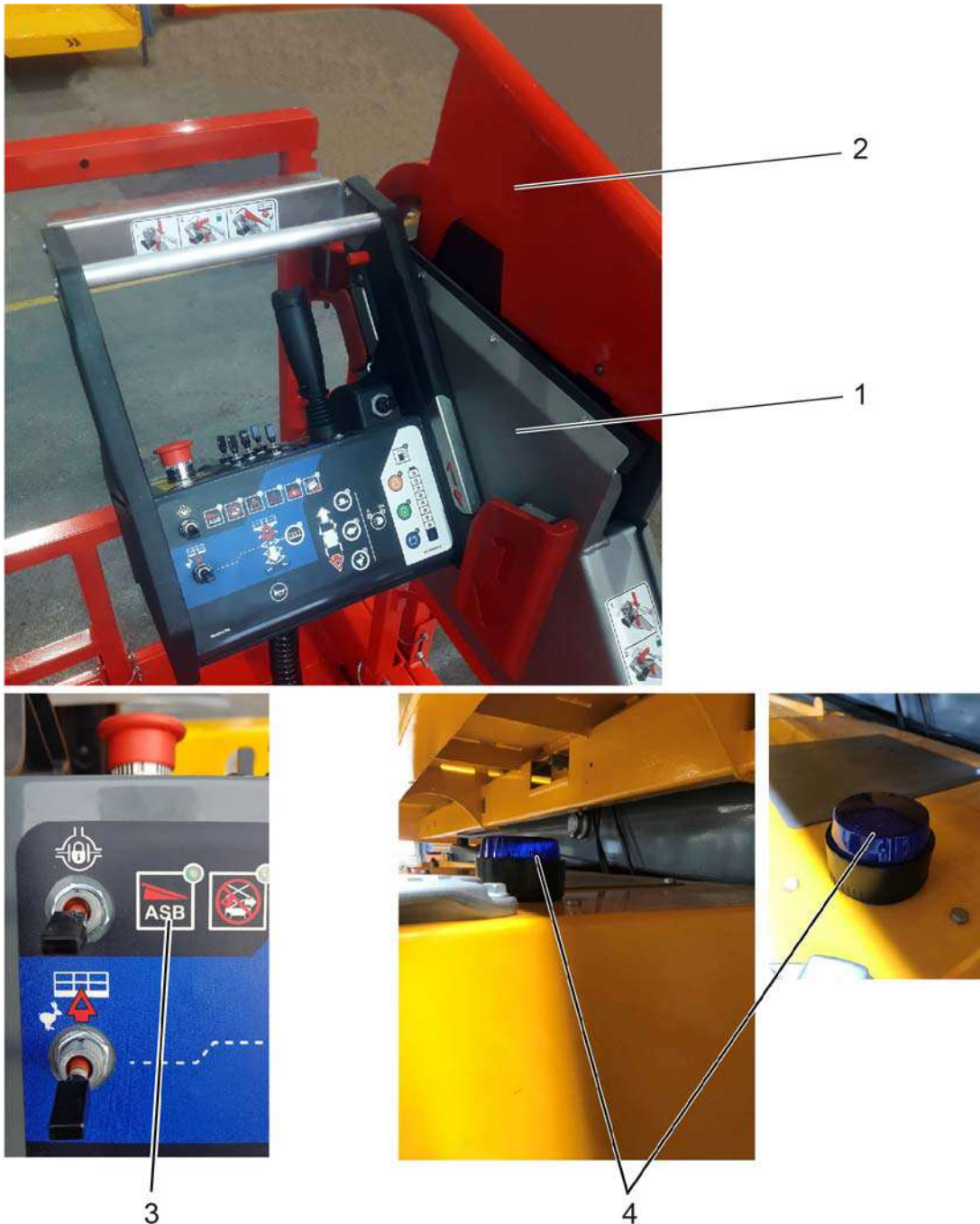

Marking	Description
1	Carrier
2	Activation bar
3	Green lighting (On the upper control console)
4	Blue flashing light (On the lower control console compartment)

E - General Specifications

5.1.3 - Safety precautions



It is mandatory to ensure that the **Activ'Shield Bar Scissors** is functional at each start-up of the machine.



Do not use the **Activ'Shield Bar Scissors** as a handhold. This could result in an inadvertent triggering of the **Activ' Shield Bar**.

5.1.4 - Pre-operation inspection



- If any item on the checklist is marked **NO** during the inspection; machine must be tagged and locked out and placed out of service.
- **DO NOT** operate the machine until all identified items are corrected and it has been declared safe for operation.

In addition to all the functional tests specific to the machine and to ensure that the **Activ'Shield Bar Scissors** system operates correctly, carry out the following operations :

Description	Yes	No
• Check that the Activ'Shield Bar Scissors parts are present and in good condition		
• Is the control console correctly assembled according to the labels?		
• Does the control console lock automatically?		
Set the console into its support :		
• Move the detection bar until it comes into contact with the console :		
• Does detection bar go all the way down?		
• Does the detection bar return to its initial position?		
Machine stowed :		
• Check the speed reduction :		
• Console out of its support, perform a lifting movement and verify that the speed is reduced. Ensure that the activation of the switch Activ' Screen (29) does not change the movement speed		
• Console in its support, perform a lifting movement and verify that the speed is reduced. Ensure that the activation of the switch Activ' Screen (29) accelerates the raising speed.		
• Select high-speed drive : Does speed selection automatically switch to medium speed?		
• Is high speed in forward gear accessible when the control console is in its support?		
• Position the control console in its support : The Activ'Shield Bar Scissors indicator light is off		
• With the control console inserted into its support, perform a lifting movement : Does the Activ'Shield Bar Scissors indicator light switch on?		
• Machine unfolded : With the control console inserted into its support, perform a lifting movement :		
Press the bar :		
• Does the machine stop?		
• Does the blue flashing light switch on?		
• Is the buzzer triggered?		
• Is downward movement possible?		
• Is rearming possible?(1)		

(1) : Reset = Bar lifted + Joystick returned to neutral

E - General Specifications

5.1.5 - Operation

Travel speed limitation (Activ'Shield Bar Scissors option)

The machine has 3 drive speeds :

- Low speed (27)
- Middle speed (26)
- Fast speed (25)

2 other speeds are activated automatically depending on the conditions of use :

- Micro-speed
- Nano speed
- The electronic speed controller controls travel speeds.
- The variable speed drive receives information from the control on the type of movements to be performed.
- The variable speed drive also manages the safety status.

Poor knowledge of the characteristics and operation of the machine can lead the operator to think that a normal safety operation is a malfunction

Machine stowed (Transport position) :

- The top control console is attached to its support (Normal operation) :
 - All travel speeds (PV, MV, GV) are permitted in forward mode. Only (PV, MV) are available in reverse.
 - The Activ'Shield Bar Scissors system is inactive (Activ'Shield Bar Scissors indicator light is off).
- The upper control console is not in its support :
 - The Activ'Shield Bar Scissors system is inactive (Activ'Shield Bar Scissors indicator light is off).
 - Only low and average speeds (PV, MV) are permitted in the 2 directions.
 - Selecting high speed (GV) automatically activates average speed (MV).

Machine unfolded (Out of transport position) :

- The top control console is attached to its support (Normal operation) :
 - The Activ'Shield Bar Scissors system is active in reverse.
 - Whatever the speed selected :
 - Forward movement is done at "Micro Speed".
 - Rear movement is done at "Nano Speed".
- The upper control console is not in its support :
 - The Activ'Shield Bar Scissors system is inactive (Activ'Shield Bar Scissors indicator light is off).
 - Only "Nano Speed" is active in the 2 movement directions.

E- General Specifications

Raising speed limitation (Activ'Shield Bar Scissors option)

The machine has 2 speeds that activate automatically depending on the conditions of use :

- Standard speed
- Safe speed

The top control console is attached to its support (Normal operation) :

- Pressing and holding the Activ'Shield Bar Scissors (29) button activates the standard raising speed and the Activ'Shield Bar Scissors system is active (The Activ'Shield Bar Scissors indicator light switches on).
- Without pressing the Activ'Shield Bar Scissors button, the safe raising speed is activated and the Activ'Shield Bar Scissors system is active (The Activ'Shield Bar Scissors indicator light switches on).
- When the machine is in the stowed position, the Activ'Shield Bar Scissors indicator light is off. When raising, the Activ'Shield Bar Scissors indicator light is on.

The upper control console is not in its support :

- The Activ'Shield Bar Scissors system is inactive (Activ'Shield Bar Scissors indicator light is off).
- Only the safe raising speed is activated (Activ'Shield Bar Scissors indicator light is off)

E - General Specifications

5.1.6 - Specific decals

 Section B 5 Decals and markings locations

5.1.7 - Insert the console into its support

Activ' Shield Bar Scissor instructions

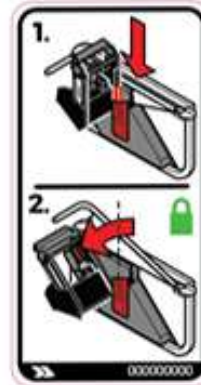

1 — Locate notches (1) and (2) on the support Activ' Shield Bar Scissor



2 — On the console, locate the identifying mark (1)



E- General Specifications

3 — Position mark (1) on the control panel vertically in mark (1) of the support



4 — Tilt the control console and snap it into the position marked (2) on support Activ' Shield Bar Scissor



5 — To remove the console, carry out the steps in reverse order. Press on the lock to unlock it.

E - General Specifications

5.2 - RANGE EXTENDER

5.2.1 - Description

This option is designed to charge the machine independently if a power network is not available nearby.

This option is used to power tools in the sockets on the RANGE EXTENDER control panel or to power the platform supply option (if present on the machine).

N.B.-:THE RANGE EXTENDER CAN ONLY FUNCTION IF THE FAST CHARGE OPTION IS AVAILABLE ON THE MACHINE.

All lifting and forward movements are possible with a machine equipped with the Range Extender system, as long as the batteries have a sufficient charge level.

5.2.2 - Characteristics

R a n g e E x t e n d e r — 1



Marking	Description
1	Engine maintenance hatch

E- General Specifications

Range Extender — 2

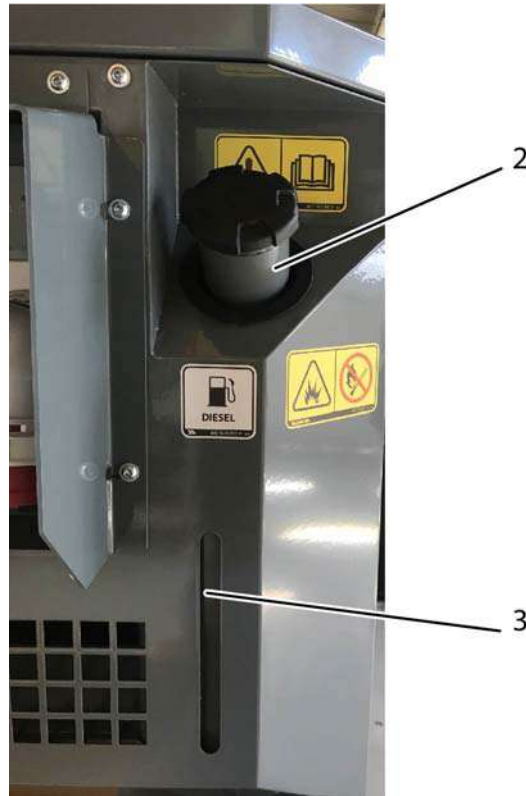

Marking	Description
2	Fuel filter
3	Fuel gauge

E - General Specifications

Range Extender — 3

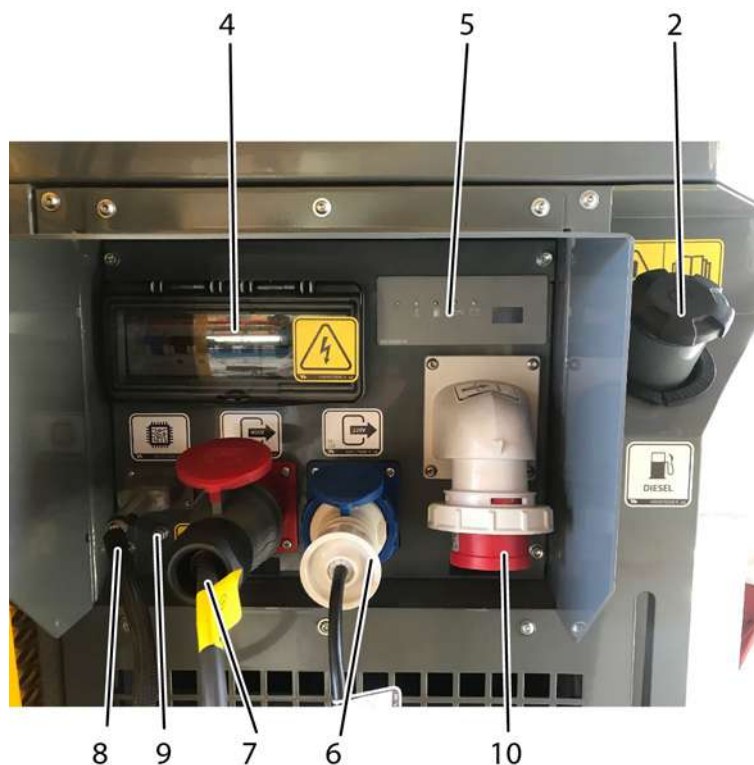

Marking	Description
2	Fuel filter
4	Circuit breaker panel
5	Display
6	Platform supply socket
7	Fast charge socket
8	Control socket
9	Earth connection
10	Socket for extension if charged from a 400 V mains

E- General Specifications

Range Extender — 4

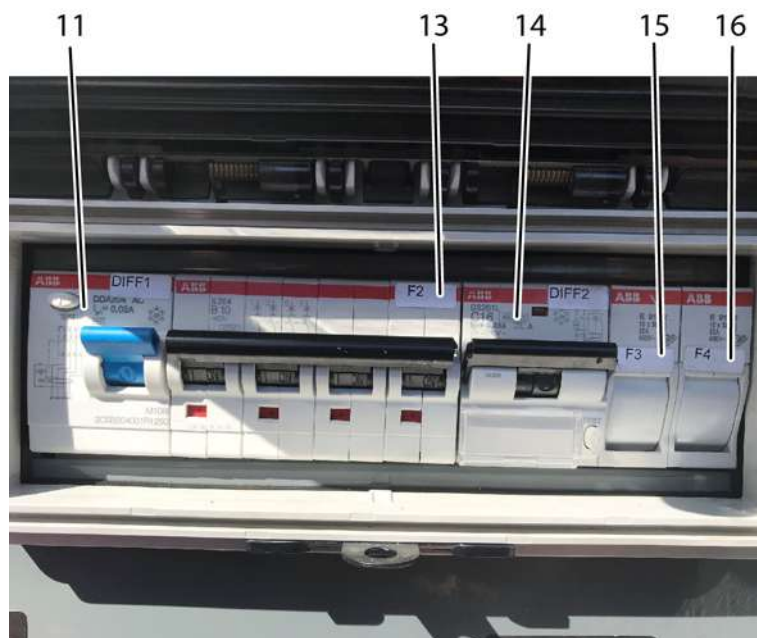

Marking	Description
11	Q3 — Differential circuit breaker
13	Q2 — Differential circuit breaker
14	Q1 — Single-phase thermal magnetic and differential circuit breaker
15	F3 — Range Extender + 12V fuse
16	F4 — Range Extender preheating fuse

Range Extender — 5

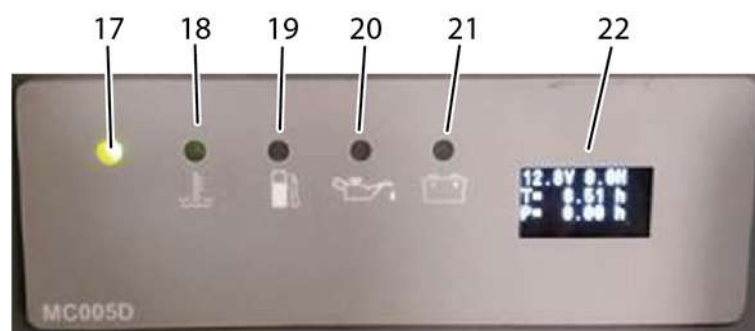

Marking	Description
17	Power supply / Ready to start — Green
18	Engine oil overheat — Red
19	Fuel reserve indicator — Red
20	Low oil pressure — Red
21	Starting battery recharge fault — Red
22	Starting battery voltage, hour meter, voltage display

E - General Specifications

	CE, EAC and AS standards	For UKCA only	ANSI and CSA standards
Dimensions (Length / Width / Height)	1250 mm x 622 mm x 812 mm / 4 ft 6 in x 25 in x 32 in	1250 mm x 622 mm x 812 mm / 4 ft 6 in x 25 in x 32 in	1250 mm x 622 mm x 812 mm / 4 ft 6 in x 25 in x 32 in
Weight	254 kg / 560 lb		
Fuel type	Diesel		
Fuel tank capacity	20 l / 5 gal		
Power	4,7 kW		4,9 kW
Noise emission level	102 dBA		
Frequency	50 Hz		60 Hz
Voltage	230 / 400 V	110 / 400 V	110 / 240 V
Frequency	16 A		15 A / 25 A

A

B

C

D

➔ E

F

G

H

I

E- General Specifications

5.2.3 - Safety precautions



Refer to the manufacturer's manual for more information (supplied with the Range Extender).



- Please read and assimilate the instructions before using the attachment.
- Do not operate the Range Extender in enclosed areas.
- The Range Extender must only be operated on the machine.
- During storage, protect the Range Extender in a safe and stable place.
- In wet weather, protect the Range Extender in a safe and stable place.
- There is a risk of burns if contact is made with the Range Extender, whether in operation or switched off, due to contact with hot parts.
- Do not fill the fuel tank or carry out maintenance operations when the engine is running.
- Do not smoke when working around the battery or when refueling
- Do not touch hot components. By touching a functioning engine, there is a risk of burns from contact with hot parts, and injuries by the rotating parts. Do not allow children to approach the machine while the engine is running
- Be sure to conduct daily checks, periodic maintenance, refueling or cleaning on a level surface with the engine shut off and remove the key.
- Whilst the machine is not in use, care must be taken to ensure that if the machine is not locked in a secure location, that the unit key switch is removed to prevent unauthorised use of the machine
- Reinstall safeguards and shields securely and clear all maintenance tools when starting the engine after maintenance.
- Do not work in an explosive or flammable atmosphere (spark, flame, etc.).
- Do not use water to extinguish a fire. Use the specific systems in place (Powder extinguishers etc.).
- The technician should ensure that suitable PPE (personal protective equipment) for the job is used, and check the particular conditions of environment in which the material can be found (see safety information specific to the operation site). Avoid direct bodily contact with fuel, engine oil and battery acid. In the event of contact with the skin, wash with water and soap, and rinse thoroughly. Do not use organic solvents. In the event of inhalation or ingestion, seek medical attention.

5.2.4 - Pre-operation inspection

- Ensure that the Range Extender is correctly affixed to the machine.
- Check engine fuel level.
- Check that there are no objects obstructing the Range Extender air vents and preventing air from passing through.

E - General Specifications

5.2.5 - Installing / Removing the Range Extender

- Position the machine on a flat and firm surface, clear of obstructions (beware of power lines).
- Stow the machine.
- Mark out the work area.
- Switch off the ignition and remove the ignition key
- Place a do not operate tag at the start/stop switch location to inform personnel that the equipment is being worked on
- Using a hand truck with forks, bring the Range extender to its support and fit it



Do not slide the Range extender into its support but set it in



- Tighten the 3 fastening screws to a torque of 76 Nm



Do not tighten the screws, which can cause the Range extender to tip over.



E- General Specifications

Fast charge connection

Connect in the order indicated :

- (8) —Control socket
- (7) —Fast charge socket
- (6) —Platform supply socket (If this option is available)

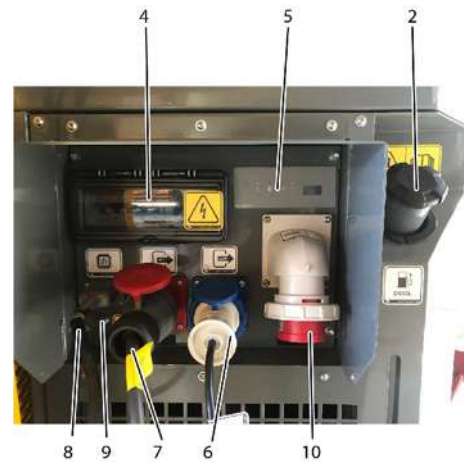

Fast charge connection — From the mains

- With the Range Extender off, connect the 400 V extension to the socket (10) to enable charging from the mains

N.B.-:-ONLY RAISING IS POSSIBLE IN THIS CASE.

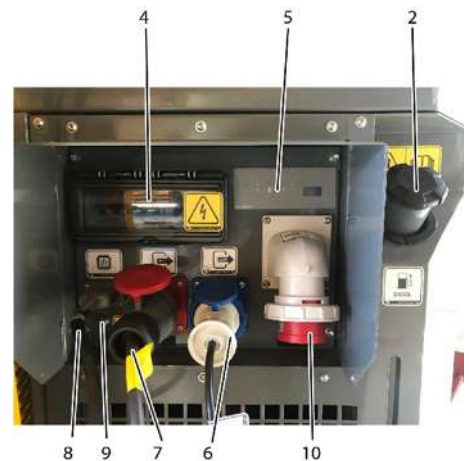

Anti-theft system :

- A padlock can be installed to prevent the Range Extender from being stolen Not supplied with the machine

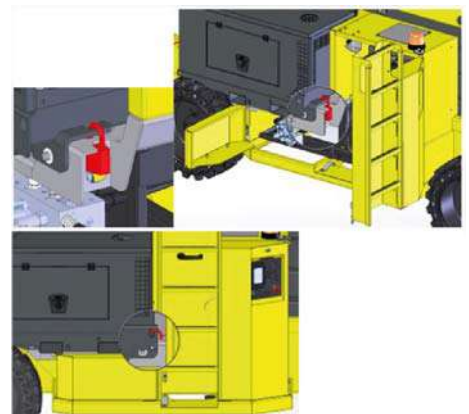

E - General Specifications

Removal :

- Switch off the ignition and remove the ignition key
- Carry out the operations in the reverse order.

N.B.-:-STOW THE SOCKETS (3) IN THEIR HOUSINGS



5.2.6 - Specific decals

 Section B 5Decals and markings locations

E - General Specifications

5.3 - FAST CHARGE

5.3.1 - Description

This option is designed to charge the machine from an available three-phase 380 V (250V US) power network to minimise the machine's charge time.

N.B.:-IF THE STANDARD SOCKET AND FAST CHARGE SOCKET ARE BOTH CONNECTED, THE MACHINE WILL AUTOMATICALLY SELECT THE CHARGE OPTION (NORMAL OR FAST) BASED ON THE FIRST SOCKET CONNECTED.

Only the platform raising function and the stabilizers are available in this configuration.

5.3.2 - Safety precautions



- Do not expose the payload to direct contact with splashes of water or a high-pressure cleaner.
- Never replace the charging cable without written permission from HAULOTTE®.
- Ensure that the mains supply is suitable for your requirements.
- The power supply must comply with the electrical standards in force.



Ensure that :

- The vents on the battery compartment must not be obstructed
- Cables must not be damaged.
- Sockets and cables must not be immersed in water or any other liquid

5.3.3 - Specifications

	CE, UKCA, AS and EAC standards	ANSI and CSA standards
Type	3 (Phase — Neutral — Ground)	
Calibre	16 A	
Voltage	380 V	250 V
Charging time — 100%	Between 7 h and 12 h	

E - General Specifications



5.3.4 - Operation



Marking	Description
1	Charger — Fast charge option
2	Three-phase connection box
3	Power plug (380V)

Connect the 380 V (250V US) power cable to the socket (3) located on the machine.

The screen Haulotte Diag switches to fast charge mode :

- Machine switched on (Wrench (21) on  — E-stop buttons are pulled out) : Fast charge starts. Only the arm raising and stabiliser functions are available in this configuration
- Machine switched off (Wrench (21) on  — E-stop buttons are pulled out) : Fast charge starts. . No movement available.

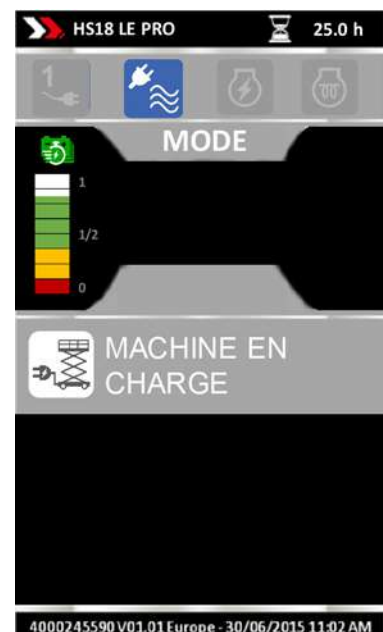

E - General Specifications

5.4 - PLATE HOLDER / TUBE HOLDER

5.4.1 - Description

This accessory is an assembly designed to transport plates, pipes and tubes. This accessory is composed of 2 supports positioned and attached on the guardrails of the platform extensions. This accessory is held in position by means of pins.

The plates, tubes or pipes must be positioned on the supports and firmly attached to them using fasteners such as lashing straps (not provided).

5.4.2 - Characteristics

Specifications	SI	Imp.
Weight of the carrier	2 x 19 kg	41.88 lb
Maximum usage load	400 kg	881.84 lb
Maximum load surface	1,2 m x 3,05 m= 1,66 m ²	3 ft 11 in x 10 ft = 17.87 sq ft
Max. dimensions of the plates/panels	1,2 m x 3,05 m	3 ft 11 in x 10 ft
Max. dimensions of the tubes/pipes	<ul style="list-style-type: none"> • Platform L : 6 m • Platform XL : 7,5 m 	<ul style="list-style-type: none"> • Platform L : 19 ft 8 in • Platform XL : 24 ft 7 in
Distance between the 2 supports — Platform L :		
• Closed extension (Minimum)	• 217 cm	• 86 in
• Extensions open (maxi)	• 414 cm	• 163 in
Distance between the 2 supports — Platform XL :		
• Closed extension (Minimum)	• 269 cm	• 106 in
• Extensions open (maxi)	• 524 cm	• 167 in
Maximum wind speed allowed	45 km/h	27 mph
Maximum number of people authorised on the work platform when the accessory is in use		3

E - General Specifications

Plate holder usage

- Maximum width : 126 cm / 50 in
- Minimum width : 81 cm / 32 in



Tube holder usage

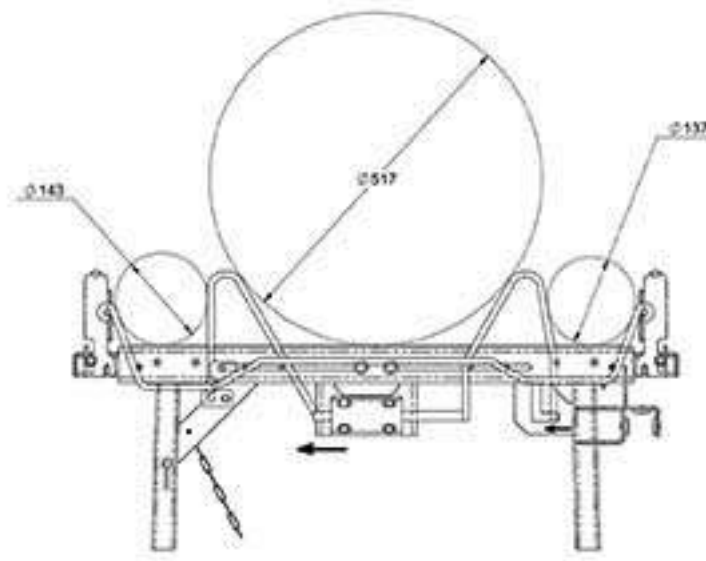

E- General Specifications

5.4.3 - Safety precautions

- Read and understand all the instructions before using the accessory.
- This accessory is designed to transport plates, panels, tubes and pipes. Do not use this attachment for transporting other types of load.
- Do not load the accessory beyond its maximum usage load.
- Ensure that the equipment is correctly attached using suitable means of securing.
- Do not exceed the nominal capacity of the platform including :
 - The weight of the accessory.
 - The weight of the load on the accessory.
 - The weight of the operators
 - The weight of the tools and any other equipment on the work platform.



Risk of overturning the machine :

- **Do not load plates, panels, tubes or pipes the surface of which exceeds the maximum authorised surface. Exposing an additional surface area to the wind reduces machine stability.**
- **Do not install any other attachments that increase the surface area exposed to the wind.**
- **Do not use the machine if the wind speed exceeds the authorized limit of the attachment.**
- **The cradles should always be positioned such that they are within the platform.**
- **Position the bottom end of the cradles such that they are resting on the platform floor.**



Risk of crushing and collision :

- **The tubes or plates installed on the equipment can modify the overall size of the machine. When maneuvering, ensure you maintain a safe distance between the load and the obstacles in the work environment.**

E - General Specifications

5.4.4 - Pre-operation inspection



- Check that there are no cracks or other damage on the supports.
- Check that the supports are correctly attached to the platform (Ensure fastening screws are tightened and pins correctly positioned).
- Check that the legs of the supports rest completely flat on the platform.
- Check that the label giving information about the machine and equipment is present and legible.
- Ensure that the means for fastening and securing the loads (e.g. straps) are in good condition and well-maintained.
- Check that the positioning of the load and the supports does not block the work platform controls and access.
- Check that the positioning of the supports and the load does not reduce visibility during manoeuvres in the working environment.

A

B

C

D

E

F

G

H

I

E- General Specifications

5.4.5 - Disassembly - Assembly

N.B.-:-THE 2 SUPPORTS ARE POSITIONED ON THE OPPOSITE SIDE TO THE PLATFORM CONTROL BOX. THE 2 SUPPORTS ARE LOCATED ON THE EXTENSIONS AND THE EXTENSIONS CAN BE MOVED WHEN THE OPTION IS INSTALLED. HOLES ARE PROVIDED ON THE GUARDRAILS TO ATTACH THE SUPPORTS. A PLACE IS AVAILABLE FOR EACH SUPPORT.

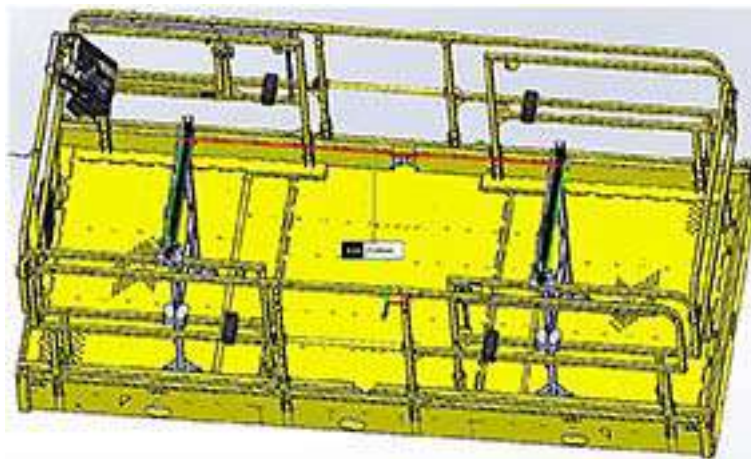

- Attach the supports to the guardrails on the opposite side to the platform control box.
- A space of 500 mm / 20 in must be left between the support and the guardrail.



E- General Specifications

- Lock the guardrail supports using the pins.

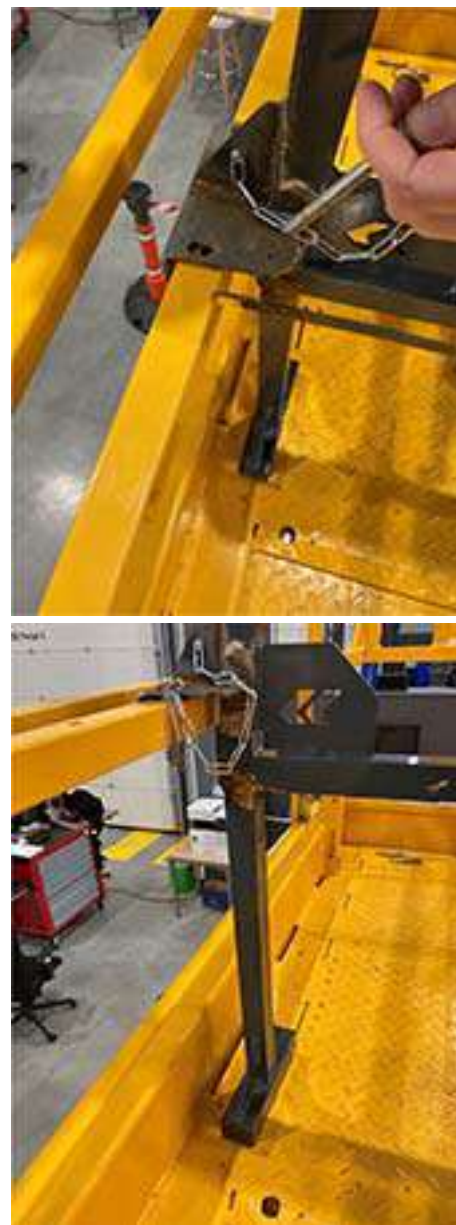

N.B.-:THE SUPPORTS ARE REMOVED IN REVERSE ORDER TO INSTALLATION.

E- General Specifications



5.4.6 - Operation

Plate/panel holder version

- Pull on the indexing pin to unlock the extensions.
- The finger automatically engages in the authorised positions.
- Ensure that the finger is locked before loading up the supports.



Operate the plate stop to place it in different positions.

Plate/panel holder position	Tube/pipe holder position — Transport position
	

E- General Specifications

Tube/pipe holder version

- Unlock the support from its seating in order to operate it.
- Lift the support manually.



- Lock the support in its seating.



E - General Specifications

- Secure the support using pins.



A

B

C

D

E

F

G

H

I

E- General Specifications

5.4.7 - Strapping (Strap not provided)

- Lift the plate stop to a vertical position.



- The supports have pins allowing lashing straps to be attached



Ensure that loads are lashed to the equipment before moving the machine.



E - General Specifications

5.4.8 - Storage of the supports on the platform

- Group the 2 supports at the rear of the platform in the opposite corner to the platform control box.
- The 2 supports are attached and locked on the guardrail using a pin.

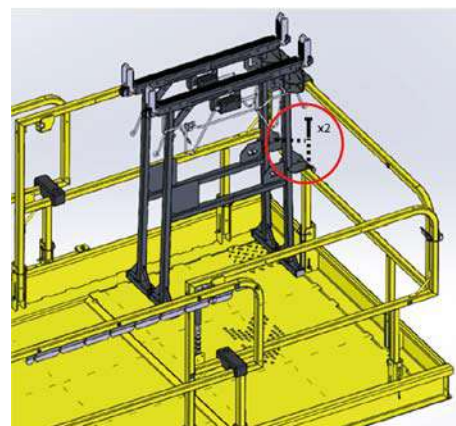

5.4.9 - Folding guardrails if machine equipped with plate/tube holder support

Storage of the supports on the work platform for transport :

- Position the supports in the centre of the platform (not on the extensions).



Assembly folded :

-  Section D 5.4 Folding guardrails



F - Maintenance

1 - General

As an owner and/or operator of Haulotte equipment, your Safety is of utmost importance to HAULOTTE®, which is why HAULOTTE® places such a high priority on product safety.

INSPECTIONS are not only required by HAULOTTE®, but may also be required by industry standards and/or local regulations.

To ensure your equipment continues to achieve the level of performance set in the factory, it is important to maintain it regularly. We remind you that it is strictly forbidden to make any modifications. Regular and timely inspections will reduce equipment down time as well as prevent possible injury.

N.B.-:-DO NOT OPERATE UNLESS YOU ARE FAMILIAR AND TRAINED IN THE PRINCIPLES OF SAFE MACHINE OPERATION.

Overview :

- Walk-around inspections take only a few minutes at the beginning and end of each shift – one of the best ways to prevent mechanical problems and safety hazards.

What to Do :

- Use your senses: sight, smell, hearing and touch.

Frequency :

- Check your machine periodically during your entire workday.
- Make sure to do your inspection the same way every time.
- Complete one of these inspections at the start and end of each shift.

N.B.-:-IF DAMAGE OR UNAUTHORIZED MODIFICATIONS ARE DISCOVERED, THE MACHINE MUST BE REMOVED FROM SERVICE UNTIL REPAIRS ARE MADE BY A QUALIFIED SERVICE TECHNICIAN.

It is the owner's responsibility to ensure the required maintenance as recommended by Haulotte is completed prior to the operation of the machine. 

If regular maintenance is not carried out, this may :

- Void the warranty.
- Cause machine malfunction.
- Reduce machine reliability and shorten its service life.
- Jeopardize operator safety.

HAULOTTE Services® technicians are specially trained to carry out extensive repairs, interventions or adjustments on the safety systems or elements of HAULOTTE® machines. They carry genuine HAULOTTE spare parts and tools as required, and also provide fully documented reports on all work completed.

The inspection and maintenance table, identifies the role and the responsibilities of each party in periodical machine maintenance.  Section C 3 - Inspection and Functional test.

F - Maintenance

2 - Maintenance Schedule

This section provides the necessary information needed to place the machine in safe operation. In accordance with the regulations that are currently applicable, this machine is designed to have a 10 year life span in normal usage conditions. The life may be extended or reduced dependent on the severity of operating conditions, the machine condition itself and by conducting effective inspections and maintenance in addition to other external factors. There are a number of factors which can affect the design life including but not limited to, severity of operating conditions/routine maintenance which should be carried out in accordance with this manual.

Severity of operating conditions may require a reduction in time between maintenance periods. Machines that have been out of service or have not been in use for more than 3 months must undergo a periodic inspection before the machine is put back into service.

Maintenance must be carried out by a competent company or person familiar with mechanical procedures.

Maintenance operations performed must be recorded in a register / log book of the machine.

F - Maintenance

3 - Inspection program

3.1 - GENERAL PROGRAM

The machine must be inspected on a regular basis at intervals of no less than once 1 per year. The purpose of the inspection is to detect any defect which could lead to an accident during routine use of the machine. Local standards and regulations may require more frequent inspections.

HAULOTTE® requires Reinforced and Major Inspections to be carried out on the product to extend its service life.

Inspections must be carried out by a competent company or person.

The inspection results must be recorded in the safety register or machine log book controlled and overseen by the company manager. This register or machine log book and the list of competent repair persons must be made available to the government work inspector and HAULOTTE Services®.

When	Responsible	Stakeholder	What
Before sale	Owner (or renter)	Competent technician or qualified technician HAULOTTE Services®	Periodic inspection
Before rent	Owner (or renter)	Competent technician or qualified technician HAULOTTE Services®	Daily inspection
Before use or every change of user	User	User	Daily inspection
Annually (1 year)	Owner (or renter)	Competent technician or qualified technician HAULOTTE Services®	Periodic inspection
5 years	Owner (or renter)	Qualified technician HAULOTTE Services®	Reinforced inspection
10 years	Owner (or renter)	Qualified technician HAULOTTE Services®	Major inspection

F - Maintenance

3.2 - DAILY INSPECTION

The Daily inspection includes a visual inspection, operational checks and testing of the safety systems. This must be conducted by the operator before using the machine.

This inspection is the responsibility of the user. Refer to  Section C 3.1 - Daily inspection.

3.3 - PERIODIC INSPECTION

The Periodic inspection is a thorough evaluation of the operation and safety features of the machine.

It must be conducted before the sale / resale of the machine and/or at least once every year.

Local regulations may have specific requirements on frequency, and content of inspections.

The severity of operating conditions may require frequent inspections.

This inspection is the responsibility of the owner, and inspections must be carried out by a competent company or person.

This inspection is in addition to the daily inspection.

This inspection should also be conducted after :

- Extensive dismantling and reassembly of major components.
- Repairs involving the machine's essential components.
- Any accident causing stress to the machine.

3.4 - REINFORCED INSPECTION

The Reinforced inspection is a thorough evaluation of the machine's structural components, to ensure proper functionality of the machine.

This evaluation must occur at a frequency of 5000 hours or every 5 years.

This inspection is the responsibility of the owner, and it must be conducted by a HAULOTTE Services® technician or by a competent company or person.

This inspection includes :

- Daily inspection
- Periodic inspection

N.B.-:-REFER TO THE MAINTENANCE MANUAL FOR DETAILS.

F - Maintenance

3.5 - MAJOR INSPECTION

The Major inspection is a thorough evaluation of the machine's integrity and proper functioning; after a normal service life of 10 years.

This evaluation must take place after 10 years of operation and then repeated every 5 years thereafter.

The severity of operating conditions may require frequent inspections.

This inspection is the responsibility of the owner, and it must be conducted by a HAULOTTE Services® technician or by a competent company or person.

This inspection includes :

- Daily inspection
- Periodic inspection
- Reinforced inspection

N.B.-:REFER TO THE MAINTENANCE MANUAL FOR DETAILS.

A

B

C

D

E

F

G

H

I

F - Maintenance

4 - Repairs and adjustments

Extensive repairs, interventions or adjustments on the safety systems or components must be performed by a HAULOTTE Services® technician. Use original spare parts and components only.

N.B.-:HAULOTTE SERVICES® TECHNICIANS ARE TRAINED PROFESSIONALS TO PERFORM EXTENSIVE REPAIRS, INTERVENTIONS AND ADJUSTMENTS ON THE SAFETY SYSTEMS OR COMPONENTS OF HAULOTTE® MACHINES. THE TECHNICIAN CARRIES GENUINE HAULOTTE® SPARE PARTS AND TOOLS AS REQUIRED, AND ALSO PROVIDES FULLY DOCUMENTED REPORTS ON ALL WORK COMPLETED.

HAULOTTE Services® will not take responsibility for any outcomes resulting from inferior services or repairs performed by other unauthorised personnel.

HAULOTTE® reminds that NO modifications SHALL be carried out without the written permission of HAULOTTE®.

Any unauthorised repairs/modifications will void HAULOTTE® warranty.

To check for safety campaigns, consult our website : www.haulotte.com



N.B.-:WHEN DISPOSING OR SCRAPPING THIS MACHINE, PLEASE CONSIDER APPROPRIATE METHODS OF RECYCLING. ANY ITEMS THAT REQUIRE SPECIFIC DISPOSAL ARE LISTED WITH INSTRUCTIONS IN THE MAINTENANCE MANUAL.

G- Other information

1 - Conditions of warranty

Our warranty conditions and extension contracts are now available on the websites of our sales network : www.haulotte.com







2 - Subsidiary contact information

	<p>HAULOTTE FRANCE PARC DES LUMIERES 601 RUE NICEPHORE NIEPCE 69800 SAINT-PRIEST TECHNICAL Department: +33 (0)820 200 089 SPARE PARTS : +33 (0)820 205 344 FAX : +33 (0)4 72 88 01 43 E-mail : haulottefrance@haulotte.com www.haulotte.fr</p>		<p>HAULOTTE ITALIA VIA LOMBARDBIA 15 20098 SAN GIULIANO MILANESE (MI) TEL: +39 02 98 97 01 FAX: +39 02 9897 01 25 E-mail : haulotteitalia@haulotte.com www.haulotte.it</p>		<p>HAULOTTE INDIA Unit No. 1205, 12th floor, Bhumiraj Costarica, Plot No. 1&2, Sector 18, Palm Beach Road, Sanpada, Navi Mumbai- 400 705 Maharashtra, INDIA Tel. : +91 22 66739531 to 35 E-mail : hlindia@haulotte.com www.haulotte.in</p>
	<p>HAULOTTE HUBARBEITSBÜHNEN GmbH Ehrenkirchener Strasse 2 D-79427 ESCHBACH TEL : +49 (0) 7634 50 67 - 0 FAX : +49 (0) 7634 50 67 - 119 E-mail : adv-gmbh@haulotte.com www.haulotte.de</p>		<p>HAULOTTE VOSTOK 61A, bld.1, RYABINOVAYA STREET 121471 MOSCOW RUSSIA TEL/FAX : +7 495 221 53 02 / 03 E-mail : salesrus@haulotte.com www.haulottevostok.ru</p>		<p>HAULOTTE DO BRASIL Av. Alameda Caiapós, 589 CEP: 06460-110 – TAMBORE BARUERI – SAO PAULO – BRASIL TEL : +55 11 4196 4300 FAX : +55 11 4196 4316 E-mail : haulottebrasil@haulotte.com www.haulotte.com.br</p>
	<p>HAULOTTE IBERICA C/ARGENTINA Nº 13 - P.I. LA GARENA 28806 ALCALA DE HENARES MADRID TEL : +34 902 886 455 TEL SAT : +34 902 886 444 FAX : +34 911 341 844 E-mail : iberica@haulotte.com www.haulotte.es</p>		<p>HAULOTTE POLSKA Sp. Z.o.o. UL. GRANICZNA 22 05-090 RASZYN - JANKI TEL : +48 22 720 08 80 FAX : +48 22 720 35 06 E-mail : E-mail : haulottepolska@haulotte.com www.haulotte.pl</p>		<p>HAULOTTE MÉXICO, S.A. de C.V. Calle 40 SUR ESQUINA 13 ESTE No. 5/N Colonia CIVAC, JUITEPEC, MORELOS CP 62578 México TEL : +52 77 7321 7923 FAX : +52 77 7516 8234 E-mail : haulotte.mexico@haulotte.com www.haulotte.com.mx</p>
	<p>HAULOTTE in JAPAN SBJ ShinOsaka BLDG 3F 4-6-5 Nishinakajima Yodogawa-ku, Osaka, JAPAN, Post Code: 532-0011 TEL : +81 6 6795 9008 FAX : +81 6 6795 9009 www.haulotte.com</p>		<p>HAULOTTE SINGAPORE Pte Ltd. No.26 CHANGI NORTH WAY, SINGAPORE 498812 Parts and service Hotline: +65 6546 6150 FAX : +65 6536 3969 E-mail : haulotteasia@haulotte.com www.haulotte.sg</p>		<p>HAULOTTE MIDDLE EAST FZE PO BOX 293881 Dubai Airport Free Zone DUBAI United Arab Emirates TEL : +971 (0)4 299 77 35 FAX : +971 (0) 4 299 60 28 E-mail : haulottemiddle-east@haulotte.com www.haulotte.ae</p>
	<p>HAULOTTE SCANDINAVIA AB Taljegårdsgatan 12 431 53 Mölndal SWEDEN TEL : +46 31 744 32 90 FAX : +46 31 744 32 99 E-mail : info@se.haulotte.com spares@se.haulotte.com www.haulotte.se</p>		<p>HAULOTTE TRADING (SHANGHAI) Co. Ltd. #7 WORKSHOP No 191 HUA JIN ROAD MIN HANG DISTRICT SHANGHAI 201108 CHINA TEL : +86 21 6442 6610 FAX : +86 21 6442 6619 E-mail : haulotteshanghai@haulotte.com www.haulotte.cn</p>		<p>HAULOTTE ARGENTINA Ruta Panamericana Km. 34,300 (Ramal A Escobar) 1615 Gran Bourg (Provincia de Buenos Aires) Argentina TEL : +54 33 27 445991 FAX : +54 33 27 452191 E-mail : haulotteargentina@haulotte.com www.haulotte.com.ar</p>
	<p>HAULOTTE UK Ltd 1 Gravely Way Four Ashes Wolverhampton WV10 7GW ENGLAND TEL : +44 (0)1216 199753 FAX : +44 (0)1952 292758 E-mail : salesuk@haulotte.com www.haulotte.co.uk</p>		<p>HAULOTTE GROUP / BILJAX 125 TAYLOR PARKWAY ARCHBOLD, OH 43502 – USA TEL : +1 419 445 8915 FAX : +1 419 445 0367 Toll free : +1 800 537 0540 E-mail : sales@us.haulotte.com www.haulotte-usa.com</p>		<p>HAULOTTE NORTH AMERICA 3409 Chandler Creek Rd. VIRGINIA BEACH, VA 23453 – USA TEL : +1 757 689 2146 FAX : +1 757 689 2175 Toll free : +1 800 537 0540 E-mail : sales@us.haulotte.com www.haulotte-usa.com</p>
	<p>HAULOTTE NETHERLANDS BV Koopvaardijweg 26 4906 CV OOSTERHOUT - Nederland TEL : +31 (0) 162 670 707 FAX : +31 (0) 162 670 710 E-mail : info@haulotte.nl www.haulotte.nl</p>		<p>HAULOTTE AUSTRALIA PTY Ltd 51 Port Link Drive DANDENONG – VIC – 3175 TEL : 1 300 207 683 FAX : +61 (0)3 9792 1011 E-mail : sales@haulotte.com.au www.haulotte.com.au</p>		<p>HAULOTTE CHILE Panamerica Norte Altura Km 21,5 Colina (Cruce c/Lo Pinto) Santiago (RM) TEL : +562 2 3727630 E-mail : haulotte-chile@haulotte.com www.haulotte-chile.com</p>

G- Other information

2.1 - CALIFORNIA WARNING

**F o r t h e U S d e s t i n e d m a c h i n e s (A N S I a n d C S A
s t a n d a r d s)**

<p>CALIFORNIA</p>  <p>Proposition 65 Warning</p> <p>Operating, servicing and maintaining a passenger vehicle or off-road vehicle can expose you to chemicals including engine exhaust, carbon monoxide, phthalates, and lead, which are known to the State of California to cause cancer and birth defects or other reproductive harm. To minimize exposure, avoid breathing exhaust, do not idle the engine except as necessary, service your vehicle in a well-ventilated area and wear gloves or wash your hands frequently when servicing your vehicle.</p> <p>For more information go to  www.P65Warnings.ca.gov/passenger-vehicle</p>
<p>CALIFORNIE</p>  <p>Avertissement de la Proposition 65</p> <p>L'exploitation, l'entretien et la maintenance d'un véhicule de tourisme ou d'un véhicule tout-terrain peuvent vous exposer à des produits chimiques, y compris les gaz d'échappement, le monoxyde de carbone, les phthalates et le plomb, identifiés par l'État de Californie comme pouvant causer le cancer et des malformations congénitales ou autres effets nocifs sur la reproduction. Pour limiter toute exposition: évitez de respirer les gaz d'échappement, ne laissez pas tourner le moteur au ralenti sauf si nécessaire, faites l'entretien du véhicule dans une zone bien aérée et portez des gants ou lavez vous fréquemment les mains lors de cette opération.</p> <p>Pour de plus amples informations, consulter  www.P65Warnings.ca.gov/passenger-vehicle</p>
<p>CALIFORNIA</p>  <p>Advertencia de la Proposición 65</p> <p>Operar, dar servicio y mantenimiento a un vehículo de pasajeros o vehículo todo terreno puede exponerle a químicos incluyendo gases del escape, monóxido de carbono, ftalatos y plomo, los cuales son conocidos por el Estado de California como causantes de cáncer y defectos de nacimiento u otros daños reproductivos. Para minimizar la exposición, evite respirar los gases del escape, no encienda el motor excepto si es necesario, dé servicio a su vehículo en un área bien ventilada y utilice guantes o lave sus manos frecuentemente cuando dé servicio a su vehículo.</p> <p>Para mayor información visite  www.P65Warnings.ca.gov/passenger-vehicle</p>

G- Other information

For electric (battery operated) machines

CALIFORNIA



Proposition 65 Warning

Battery posts, terminals and related accessories contain lead and lead compounds, chemicals known to the State of California to cause cancer and reproductive harm. Batteries also contain other chemicals known to the State of California to cause cancer.
WASH HANDS AFTER HANDLING.

For more information go to  www.P65Warnings.ca.gov

CALIFORNIE



Avertissement de la Proposition 65

Les batteries, les bornes et autres accessoires contiennent du plomb et des composés à base de plomb, agents chimiques identifiés par l'État de Californie comme pouvant provoquer le cancer et des effets nocifs sur la reproduction. Les batteries contiennent également d'autres agents chimiques identifiés par l'Etat de Californie comme pouvant provoquer le cancer.
SE LAVER LES MAINS APRES MANIPULATION.

Pour de plus amples informations, consulter  www.P65Warnings.ca.gov

CALIFORNIA



Advertencia de la Proposición 65

Los bornes, los terminales y los accesorios de las baterías contienen plomo y compuestos de plomo, químicos conocidos por el Estado de California como causantes de cáncer y daños reproductivos. Las baterías también contienen otros químicos conocidos por el Estado de California como causantes de cáncer.
LAVESE LAS MANOS DESPUES DE MANIPULARLOS.

Para mayor información visite  www.P65Warnings.ca.gov

H - Intervention register

1 - Intervention register

The intervention register keeps a record of maintenance and repair work carried out inside or outside the maintenance programme.

N.B.:-IN THE CASE OF A HAULOTTE SERVICES® INTERVENTION, THE QUALIFIED TECHNICIAN MUST INDICATE THE HAULOTTE SERVICES® INTERVENTION NUMBER.

Date	Type of intervention	Number of hours	Intervenor	HAULOTTE Services® intervention number

A

B

C

D

E

F

G

H

I

H- Intervention register

Date	Type of intervention	Number of hours	Intervenor	HAULOTTE Services® intervention number